

**MCZ**

Pellet /2016



# Scegli il tuo calore

Choose your own warmth  
Choisissez votre chaleur  
Wählen Sie Ihre Wärme aus  
Elije tu calor

p. 02

## STUFE

stoves  
poêles  
Kaminöfen  
estufas

p. 20	<b>Curve</b>	p. 82	<b>Face</b>
p. 24	<b>Mood</b>	p. 84	<b>Amy</b>
p. 28	<b>Halo</b>	p. 86	<b>Giò</b>
p. 30	<b>Aike</b>	p. 88	<b>Maggie</b>
p. 34	<b>Tilda</b>	p. 90	<b>Decò</b>
p. 38	<b>Klin</b>	p. 94	<b>Cute</b>
p. 42	<b>Lam</b>	p. 96	<b>Thema</b>
p. 46	<b>Cap</b>	p. 98	<b>Stream</b>
p. 48	<b>Tray</b>	p. 102	<b>Philo</b>
p. 52	<b>Ego</b>	p. 106	<b>Flair</b>
p. 54	<b>Star</b>	p. 108	<b>Flat</b>
p. 58	<b>Sagar</b>	p. 110	<b>Swing</b>
p. 60	<b>Suite</b>	p. 114	<b>Flux</b>
p. 64	<b>Club</b>	p. 116	<b>Ego Hydro</b>
p. 68	<b>Musa</b>	p. 118	<b>Star Hydro</b>
p. 72	<b>Tube</b>	p. 120	<b>Musa Hydro</b>
p. 74	<b>Toba</b>	p. 122	<b>Suite Hydro</b>
p. 78	<b>Nima</b>	p. 124	<b>Club Hydro</b>
p. 80	<b>Kaika</b>	p. 126	<b>Duo</b>

## CAMINETTI

fireplaces  
cheminées  
Kamine  
chimeneas

p. 128	<b>Vivo 85 Hydro</b>
p. 132	<b>Vivo 90</b>
p. 134	<b>Prime</b>
p. 136	<b>Modus</b>
p. 138	<b>Frame</b>
p. 140	<b>Boxtherm</b>

## DATI TECNICI

technical data  
données techniques  
technische Daten  
datos técnicos

p. 142

## Scegli il tuo calore

Se ami il fuoco e stai cercando una sensazione di calore completamente diversa, se vuoi aiutare il tuo impianto di riscaldamento nei periodi più freddi o se credi che il calore di una stufa possa essere sufficiente e più economico, allora scopri i nostri prodotti a pellet: belli da vedere, silenziosi, facili da usare, performanti e pensati per sfruttare tutto lo spazio di casa tua. Scegli il tuo calore, cambierai la qualità della tua vita.

## Choose your own warmth

If you love fire and are looking for an entirely different sensation of warmth, if you want to boost your heating system in the coldest times of the year or if you think the warmth of a stove might be enough as well as cheaper, then come and find out about our pellet products: they look good, they are noiseless, easy to use, high-performing and designed to make full use of all the space of your home. Choose your own warmth, you will change the quality of your life.

## Choi- sissez votre chaleur

Si vous aimez le feu et que vous êtes à la recherche d'une chaleur totalement différente, si vous désirez donner un coup de main à votre installation de chauffage dans les périodes les plus froides ou si vous pensez que la chaleur d'un poêle puisse être suffisante et plus économique, alors découvrez nos produits à pellets : beaux, silencieux, simples d'utilisation, performants et conçus pour exploiter tout l'espace de votre maison. Choisissez votre chaleur, vous changerez la qualité de votre vie.

## Wählen Sie Ihre Wärme aus

Wenn Sie das Feuer lieben und ein ganz neues Wärmegefühl suchen, wenn Sie Ihre Heizanlage in der kältesten Zeit unterstützen möchten oder glauben, dass die Wärme eines Ofens ausreichend und wirtschaftlicher sein kann, dann sollten Sie unsere Pelletprodukte kennenlernen: schön anzusehen, geräuscharm, benutzerfreundlich, mit effizienten Leistungen und dazu konzipiert, den gesamten Raum Ihres Heims zu nutzen. Wählen Sie Ihre Wärme, sie werden Ihre Lebensqualität verändern.

# Elije tu calor

Si amas el fuego y estás buscando una sensación de calor completamente diferente, si quieres ayudar a tu instalación de calefacción en los periodos más fríos o si crees que el calor de una estufa pueda ser suficiente y más económico, entonces descubre nuestros productos de pellet: bellos a la vista, silenciosos, fáciles de usar, de alto rendimiento y pensados para aprovechar todo el espacio de tu casa. Elije tu calor, cambiarás la calidad de tu vida.

# Belli da vedere e silenziosi

**GOOD-LOOKING AND NOISELESS**

**BEAUX ET SILENCIEUX**

**SCHÖN ANZUSEHEN UND GERÄUSCHARM**

**BELLOS A LA VISTA Y SILENCIOSOS**

I prodotti a pellet MCZ sono stati studiati per garantire la massima silenziosità in ambiente e una fiamma che, oltre a riscaldare, possa essere anche bella da ammirare. Grazie ad una costante ricerca sviluppata su questi aspetti, oggi i prodotti a pellet hanno livelli di silenziosità e bellezza di fiamma molto simili ai prodotti a legna, mantenendo tutti i vantaggi legati alla programmazione e alla facilità / pulizia di stoccaggio del combustibile.

MCZ pellet products are designed to ensure maximum silence in the room and to provide a flame that not only produces heat but is also appealing to look at. Thanks to constant research on these aspects, today pellet products operate silently and offer beautiful flames that are very similar to ones produced from wood, while maintaining all of the advantages connected to programming and easy / clean fuel storage.

Les produits à pellets MCZ sont conçus pour garantir un silence maximum dans la pièce et une flamme qui, en plus de chauffer, peut également être belle à regarder. Grâce à une recherche constante développée autour de ces aspects, les produits à pellets offrent actuellement un niveau de silence et de beauté de la flamme très similaire aux produits à bois, tout en conservant tous les avantages liés à la programmation et à la facilité / propreté de stockage du combustible.

Die mit Pellets beheizten Produkte von MCZ wurden entworfen, um maximale Geräuscharmheit im Raum und eine Flamme, die nicht nur wärmt, sondern auch schön anzusehen ist, zu garantieren. Dank der ständigen, auf diese Aspekte konzentrierte Forschung gleichen die Pelletöfen heute im Hinblick auf die Geräuschlosigkeit und die Schönheit der Flamme den Holzöfen und bieten gleichzeitig alle Vorteile, die mit der Programmierung und der einfachen, saubereren Lagerung des Brennstoffs verbunden sind.

Los productos de pellet MCZ han sido ideados para ofrecer el máximo silencio en el ambiente y una llama que además de calentar, puede admirarse como algo agradable a la vista. Gracias a una investigación constante en estos aspectos hoy en día los productos de pellet son muy silenciosos y cuentan con una llama agradable a la vista, lo que los hace similares a los productos que usan la leña, manteniendo todas las ventajas que conllevan la programación y la facilidad / limpieza de almacenaje del combustible.



## ZERO RUMORE

I prodotti con tecnologia “Still” sono stati progettati per abbattere ogni fonte di rumore o vibrazione interna alla stufa e annullano completamente il rumore della ventilazione.

## NOISE-FREE

“Still” technology products are designed to eliminate every source of noise or vibration inside the stove and completely block out any noise from ventilation.

## AUCUN BRUIT

Les produits intégrant la technologie “Still” sont conçus pour réduire toute source de bruit ou de vibration à l'intérieur du poêle et élimine complètement le bruit de la ventilation.

## GERÄUSCHLOS

Die Produkte mit “Still”-Technologie wurden für einen Abbau aller Lärm- oder Vibrationsquellen im Kaminofen entwickelt und beseitigen die durch die Lüftung entstehenden Geräusche komplett.

## SIN RUIDOS

Los productos con tecnología “Still” han sido proyectados para reducir al mínimo cualquier fuente de ruido o vibración que pueda generarse en el interior de la estufa y para anular completamente el ruido de la ventilación.



## VENTILAZIONE ESCLUDIBILE

La funzione No air consente di escludere totalmente la ventilazione forzata della stufa, garantendo massima silenziosità e tutto il piacere del calore diffuso in ambiente per convezione naturale.

## EXCLUDABLE VENTILATION

The No air function allows you to completely exclude forced ventilation in the stove, ensuring maximum silence and all of the advantages of heat diffused throughout the room by natural convection.

## VENTILATION DÉSACTIVABLE

La fonction “No air” permet d'exclure complètement la ventilation forcée du poêle, garantissant ainsi le silence et tout le plaisir de la chaleur diffusée dans la pièce par convection naturelle.

## AUSSCHLIESSBARE LÜFTUNG

Die Funktion “No air” ermöglicht es, die Zwangslüftung des Kaminofens völlig auszuschließen, und garantiert dadurch Geräuschlosigkeit und die Annehmlichkeit einer durch natürliche Konvektion im Raum verteilte.

## VENTILACIÓN CON POSIBILIDAD DE EXCLUSIÓN

La función No air permite excluir totalmente la ventilación forzada de la estufa, garantizando el máximo silencio posible y todo el confort del calor que se difunde en el ambiente por convección natural.



## FIAMMA NATURALE

I prodotti a pellet di ultima generazione sono caratterizzati da una fiamma ampia dal movimento più naturale e veramente bella da ammirare.

## NATURAL FLAME

Latest-generation pellet products feature a large flame with a more natural movement and truly beautiful to look at.

## FLAMME NATURELLE

Les produits à pellets de dernière génération sont caractérisés par une flamme ample au mouvement plus naturel, vraiment belle à admirer.

## NATÜRLICHE FLAMME

Die Pelletöfen der neusten Generation zeichnen sich durch eine breite Flamme mit natürlicherer Bewegung aus, die wirklich schön anzusehen ist.

## LLAMA NATURAL

Los productos de pellet de última generación se caracterizan por una llama amplia con un movimiento más natural y genuino bella de contemplar.

# Facili da usare

EASY TO USE  
SIMPLES D'UTILISATION  
BENUTZERFREUNDLICH  
FÁCILES DE USAR



## ACCENSIONE IN 3 MINUTI

Prodotto equipaggiato con candeletta in ceramica che garantisce dei tempi di accensione ridotti del 40%.

## IGNITION IN 3 MINUTES

Product equipped with ceramic spark plug ensuring ignition times reduced by 40%.

## ALLUMAGE EN 3 MINUTES

Produit équipé d'une bougie d'allumage en céramique qui garantit des temps d'allumage réduits de 40 %.

## EINSCHALTUNG IN 3 MINUTEN

Mit einer Keramikzündkerze, die um 40 % reduzierte Einschaltzeiten gewährleistet, ausgestattetetes Produkt.

## ENCENDIDO EN 3 MINUTOS

Producto equipado con bujía de cerámica que garantiza tiempos de encendido reducidos un 40%.

## BRACIERE AUTOPULENTE

Braciere autopulente a raschiamento meccanico gestito automaticamente dall'elettronica della stufa Active+.

## SELF-CLEANING BRAZIER

Self-cleaning brazier with mechanical scraping, managed automatically by the electronics of the Active+ stove.

## BRASIER AUTONETTOYANT

Brasier autonettoyant à raclement mécanique géré automatiquement par l'électronique du poêle Active+.

## SELBSTREINIGENDE BRENNSCHALE

Selbstreinigende Brennschale durch mechanisches Abschaben, es wird alles automatisch von der Elektronik des Active+ Ofens gesteuert.

## BRASERO AUTOLIMPIADOR

Brasero autolimpiador de raspado mecánico gestionado automáticamente por los dispositivos electrónicos de la estufa Active+.

## SVUOTAMENTO CENERE SETTIMANALE

L'elevata capienza del cassetto cenere consente l'utilizzo della stufa per una settimana senza svuotamenti (consumo a potenza media, funzionamento per 8 ore/giorno).

## WEEKLY ASH EMPTYING

The high capacity of the ash drawer allows the stove to be used for a week without emptying (average power consumption, 8 hours/day operation).

## VIDAGE DES CENDRES HEBDOMADAIRE

La très grande capacité du tiroir à cendres permet l'utilisation du poêle pendant une semaine sans effectuer de vidages (consommation à puissance moyenne, fonctionnement pendant 8 heures/jour).

## WÖCHENTLICHE ASCHENENTLEERUNG

Das hohe Fassungsvermögen des Aschenkastens ermöglicht den Betrieb des Ofens eine Woche lang ohne Entleeren (Verbrauch bei mittlerer Leistung, Betrieb 8 Stunden/Tag).

## VACIADO DE LAS CENIZAS SEMANAL

La elevada capacidad del cajón permite utilizar la estufa durante una semana sin necesidad de proceder a vaciados frecuentes (consumo con potencia media, funcionamiento durante 8 horas al día).

**1**

**Pannello**  
**Panel**  
**Panneau**  
**Bedienfeld**  
**Panel**

**2**

**Telecomando con funzione termostato ambiente**  
**Remote control with room thermostat function**  
**Tèlècommande avec fonction thermostat ambiance**  
**Fernbedienung mit Raumthermostatfunktion**  
**Mando con función termostato ambiente**

Programmazione giornaliera o settimanale con possibilità di scegliere temperature diverse in fasce diverse nell'arco della giornata.

Daily or weekly programming with the option to select different temperatures at different times during the day.

Programmation journalière ou hebdomadaire avec la possibilité de choisir différentes températures, sur des phases horaires différentes, réparties sur la journée.

Tages- oder Wochenprogrammierung mit der Auswahlmöglichkeit verschiedener Temperaturen in unterschiedlichen Tagesabschnitten.

Programación diaria o semanal pudiéndose elegir temperaturas diferentes en franjas diferentes durante el día.

**3**

**Smartphone e tablet**  
**Smartphone and tablet**  
**Smartphone et tablet**  
**Smartphone und tablet**  
**Smartphone y tablet**

Tramite un'applicazione (App) dedicata, è possibile gestire e programmare la stufa anche da uno smartphone o da un tablet, dentro o fuori casa (richiede un kit accessorio; compatibile con i sistemi Android / iOS). Su tutti i modelli è comunque prevista la possibilità di gestire le funzioni principali via messaggio sms (è richiesto un kit accessorio).

Through a dedicated application (App), it is possible to manage and programme the stove from your smartphone or tablet, inside or outside of the house (requires an accessory kit; compatible with the systems Android / iOS). With all models, it is nevertheless possible to manage the main functions via text message (this requires an accessory kit).

Une application (App) spéciale permet également de gérer et de programmer le poêle à l'aide d'un smartphone ou d'une tablette, à l'intérieur comme à l'extérieur de la maison (exige un kit accessoire ; compatible avec les systèmes Android / iOS). La possibilité de gérer les fonctions principales par message sms est prévue sur tous les modèles (un kit accessoire est nécessaire).

Fernbedienung kann der Kaminofen mithilfe einer dedizierten Anwendung (App) auch über ein Smartphone oder ein Tablet, im Haus oder draußen, bedient und programmiert werden (Zubehörkit erforderlich; kompatibel mit den Systemen Android / iOS). Bei allen Modellen ist jedenfalls die Möglichkeit zur Steuerung der Hauptfunktionen per SMS vorgesehen (Zubehörkit erforderlich).

Mediante una aplicación (App) específica, la estufa se puede gestionar y programar incluso desde un smartphone o desde una tableta dentro o fuera de casa (requiere de un kit accesorio; compatible con los sistemas Android/iOS). En todos los modelos además está prevista la posibilidad de gestionar las funciones principales mediante mensaje sms (es necesario un kit accesorio).





# Più performanti

HIGHER PERFORMING  
PLUS PERFORMANTS  
EFFIZIENTERE LEISTUNG  
CON ALTOS RENDIMIENTOS



## LA MIGLIORE COMBUSTIONE

Grazie ad un sensore interno alla stufa, l'aria comburente è costantemente regolata in base alla quantità di pellet presente nel braciere, garantendo così una combustione efficace ed efficiente che si traduce in minori consumi, minori emissioni e pulizie molto meno frequenti. Questa tecnologia consente inoltre di gestire tipi diversi di pellet e condizioni differenti di installazione.

## THE BEST COMBUSTION

Thanks to a sensor inside the stove, the combustion air is constantly regulated according to the amount of pellets in the burn pot, thus assuring effective and efficient combustion which turns into lower consumption, lower emissions and need to clean a lot less frequently. This technology also makes it possible to manage different types of pellet and different installation conditions.

## LA MEILLEURE COMBUSTION

Grâce à un capteur installé dans le poêle, l'air comburant est dosé constamment en fonction de la quantité de pellets dans le brasier, tout en garantissant une combustion efficace et performante ; les consommations sont par conséquent réduites, tout comme les émissions et les nettoyages sont beaucoup moins fréquents. Cette technologie permet également de gérer différents types de pellets et des solutions différentes d'installation.

## DIE BESSERE VERBRENNUNG, IMMER

Dank einem Sensor im Ofeninneren wird die Verbrennungsluft auf Grund der Menge Pellets in der Brennschale konstant reguliert, was eine wirksame und effiziente Verbrennung gewährleistet, was wiederum einen niedrigeren Verbrauch, weniger Emissionen und viel seltenere Reinigungen zur Folge hat. Diese Technologie ermöglicht außerdem die Verwendung verschiedener Pellettypen und unterschiedliche Installationsbedingungen.

## LA MEJOR COMBUSTIÓN

Gracias a un sensor en el interior de la estufa, el aire comburente está constantemente regulado según la cantidad de pellet presente en el brasero, garantizando de esta manera una combustión eficaz y eficiente que se traduce en menor consumo, menos emisiones y limpiezas mucho menos frecuentes. Esta tecnología también permite gestionar diferentes tipos de pellets y condiciones diferentes de instalación.

## NUOVE INTERFACCE UTENTE

Grazie ad Active+, è possibile comandare e dialogare con la stufa anche tramite smartphone e tablet.

## NEW USER INTERFACES

Thanks to Active+, it is possible to control and communicate with the stove from your smartphone or tablet.

## NOUVELLES INTERFACES UTILISATEUR

Grâce à Active+, il est également possible de commander et de dialoguer avec le poêle à partir d'un smartphone et d'une tablette.

## NEUE BENUTZERSCHNITTSCHELNEN

Active+ macht es möglich, den Kaminofen auch über Smartphone und Tablet zu steuern.

## NUEVAS INTERFACES DE USUARIO

Gracias a Active+, se puede controlar y comunicar con la estufa incluso mediante smartphone y tableta.



## MAGGIORE SILENZIOSITÀ

Essendo in grado di gestire i motoriduttori più evoluti (con funzionamento in continuo), le nuove stufe a pellet dotate di Active+ risultano ancora più silenziose.

## IMPROVED SILENCE

As the new pellet stoves that are equipped with Active+ are able to manage a more evolved gear motor (in continuous operation), they are even quieter.

## FONCTIONNEMENT PLUS SILENCIEUX

Étant à même de gérer les motoréducteurs les plus évolués (avec fonctionnement en continu), les nouveaux poêles équipés d'Active+ sont encore plus silencieux.

## NOCH LEISER

Dank hoch entwickelter Getriebemotoren (mit stufenlosem Betrieb) sind die neuen, mit Active+ ausgestatteten Pelletöfen noch leiser.

## MÁS SILENCIOSAS

Al ser capaces de gestionar los motorreductores más avanzados (con funcionamiento continuo), las nuevas estufas de pellet que incluyen Active+ son aún más silenciosas.

## OYSTER

Grazie ad una struttura perfettamente stagna, la stufa non consuma l'ossigeno dell'ambiente prendendo tutta l'aria dall'esterno e può quindi essere collocata all'interno di tutte le case ben isolate e all'interno delle case passive.

## OYSTER

Thanks to a perfectly sealed structure, the stove does not use up the oxygen inside the room. Instead, it draws air from the outside environment and can therefore be fitted in all well-insulated homes and in passive houses.

## OYSTER

Grâce à une structure parfaitement étanche, le poêle ne consomme pas l'oxygène de la pièce, en prenant tout l'air de l'extérieur et il peut ainsi être placé dans toutes les maisons bien isolées et à l'intérieur des maisons passives.

## OYSTER

Dank einem absolut luftdichten Aufbau verbraucht der Ofen keinen Sauerstoff aus dem Raum, sondern führt die Luft gänzlich von außen zu, sodass er in allen gut gedämmten Häusern und in Passivhäusern eingesetzt werden kann.

## OYSTER

Gracias a una estructura totalmente estanca, la estufa no consume el oxígeno del ambiente. Capta el aire desde el exterior, por lo que puede instalarse dentro de casas bien aisladas y en casas pasivas.

## ECODESIGN 2022

I nuovi prodotti sono già stati progettati tenendo conto delle severe restrizioni della normativa Ecodesign 2022 in materia di impatto ambientale.

## ECODESIGN 2022

The new products have already been designed in compliance with the stringent restrictions of the Ecodesign 2022 directive on environmental impact.

## ECODESIGN 2022

Les nouveaux produits ont déjà été conçus en tenant compte des restrictions strictes de la norme Ecodesign 2022 en matière d'incidences sur l'environnement.

## ECODESIGN 2022

Unsere Produkte sind bereits unter Berücksichtigung der in der Norm Ecodesign 2022 enthaltenen strengen Einschränkungen bezüglich der Auswirkungen auf die Umwelt entwickelt worden.

## ECODESIGN 2022

Los nuevos productos ya han sido diseñados teniendo en cuenta las rigurosas restricciones de la normativa Ecodesign 2022 en materia de impacto medioambiental.

# Pensati per sfruttare tutto lo spazio di casa tua

DESIGNED TO MAKE FULL USE OF ALL THE SPACE OF YOUR HOME  
CONÇUS POUR EXPLOITER TOUT L'ESPACE DE VOTRE MAISON  
DAZU KONZIPIERT, UM DEN GESAMTEN RAUM IHRES HEIMS ZU NUTZEN  
PENSADOS PARA APROVECHAR TODO EL ESPACIO DE TU CASA



## Spazi ristretti Confined spaces Espaces étroits In engen Räumlichkeiten Espacios estrechos

\_Grazie ad una profondità molto ridotta, questi prodotti sono particolarmente adatti per installazioni in corridoi o ambienti piccoli.

\_Thanks to a very limited depth, these products are particularly suitable in small rooms or hallways.

\_Grâce à une profondeur extrêmement réduite, ces produits sont particulièrement adaptés pour être installés dans les couloirs ou les environnements restreints.

\_Aufgrund der sehr geringen Tiefe eignen sich die Produkte besonders für Installationen in Fluren oder kleinen Räumen.

\_Gracias a una profundidad muy reducida, estos productos son especialmente adecuados para instalaciones en corredores o ambientes pequeños.

## Recupero vecchi focolari Use of old fireboxes Récupération des anciens foyers Wiederverwertung von alten Feuerräumen Recuperación de viejas chimeneas

\_Questi prodotti sono pensati per poter recuperare vecchi focolari che non funzionano e/o non scaldano, grazie ad un'altezza contenuta (stufe) e la possibilità di essere inseriti (camini).

\_These products are designed to be able to use old fireboxes that do not work and/or do not heat, thanks to a limited height (stoves) and the possibility of being incorporated (chimneys).

\_Ces produits sont conçus pour pouvoir récupérer d'anciens foyers qui ne fonctionnent et/ou ne réchauffent plus, grâce à une hauteur limitée (poêles) et à la possibilité d'être insérés (cheminées).

\_Mit diesen Erzeugnissen können alte Feuerräume, die nicht mehr beheizt werden bzw. keine Wärme abgeben, dank der geringen Höhe (Öfen) und der Einbaumöglichkeit (Kamine) erneut zum Einsatz kommen.

\_Estos productos han sido ideados para poder recuperar viejos hogares que no funcionan y/o no calientan, gracias a una altura reducida (estufas) y la posibilidad de insertarlos (chimeneas).



**Recupero canne fumarie esistenti**  
**Use of existing flues**  
**Récupération des conduits de fumée existants**  
**Wiederverwertung von bereits existierenden Schornsteinen**  
**Recuperación de conductos de humos existentes**

\_Grazie alla presenza di una uscita fumi superiore, queste stufe possono sfruttare le canne fumarie esistenti ottimizzando così lo spazio abitativo e limitando i costi di installazione.

\_Thanks to the presence of an upper flue outlet, these stoves can take advantage of the existing flues, thereby optimising the living space and reducing installation costs.

\_Grâce à la présence d'une sortie de fumées supérieure, ces poêles peuvent exploiter les conduits de fumées existants en optimisant ainsi l'espace habité et en limitant les coûts d'installation.

\_Da ein oberer Rauchauslass vorhanden ist, können die Öfen die bereits bestehenden Rauchabzüge nutzen, wodurch der Wohnraum optimiert wird und die Installationskosten verringert werden.

\_Gracias a la presencia de una salida de humos superior, estas estufas usan conductos de humos existentes, optimizando de esta forma el espacio de la habitación y limitando los costes de instalación.



**Soluzioni ad angolo**  
**Corner solutions**  
**Solutions à angle**  
**Eckenlösungen**  
**Soluciones de esquina**

\_Stufe pensate per sfruttare gli angoli di una casa, spazi tradizionalmente poco utilizzabili.

\_Stoves designed to take advantage of the corners in a home, which are generally used very little.

\_Des poêles conçus pour exploiter les angles d'une maison, espaces traditionnellement peu utilisés.

\_Öfen, mit denen die Eckbereiche eines Hauses genutzt werden - ein Freiraum, der üblicherweise nur bedingt ausgefüllt werden kann.

\_Estufas ideadas para aprovechar las esquinas de una casa, espacios tradicionalmente poco utilizados.

# Scegli il tuo calore

CHOOSE YOUR OWN WARMTH  
CHOISISSEZ VOTRE CHALEUR  
WÄHLEN SIE IHRE WÄRME AUS  
ELIJE TU CALOR



## **aria canalizzata** **ducted air** **air canalisé** **luftverteilung** **aire canalizado**

### **DIFFUSORI POSIZIONABILI FINO A 8 METRI, LIBERAMENTE**

Comfort Air® può trasportare in modo efficace l'aria calda (80°C) in altri ambienti fino a una distanza massima di 8 metri reali. A differenza dei sistemi tradizionali in cui le bocchette devono essere posizionate in alto, Comfort Air® consente invece un posizionamento delle bocchette libero (anche in prossimità del pavimento).

### **DIFFUSER POSITIONABLE UP TO 8 METRES, FREELY**

Comfort Air® can effectively carry the warm air (80°C) into other rooms up to a maximum distance of 8 meters. Unlike traditional systems in which the jets must be positioned at the top, Comfort Air® allows the jets to be freely positioned.

### **DIFFUSEURS POSITIONNABLES JUSQU'À 8 MÈTRES, LIBREMENT**

Comfort Air® peut transporter de manière efficace l'air chaud (80 °C) dans d'autres pièces jusqu'à une distance maximale réelle de 8 mètres. Différemment des systèmes traditionnels où les bouches d'air doivent être positionnées en haut, Comfort Air® permet un positionnement libre des bouches d'air.

### **VERTEILER KÖNNEN BELIEBIG BIS AUF 8 METER POSITIONIERT WERDEN**

Comfort Air® transportiert äußerst wirksam die warme Luft (80°C) bis zu einer Entfernung von maximal 8 Metern. Im Unterschied zu den herkömmlichen Systemen, bei denen die Luftaustritte nach oben gerichtet sein müssen, können bei Comfort Air® die Austritte beliebig eingestellt werden, dies bietet ohne Zweifel ästhetische Vorteile.

### **DIFUSORES POSICIONABLES HASTA A 8 METROS, CON LIBERTAD**

Comfort Air® puede transportar de forma eficaz el aire caliente (80 °C) a otras habitaciones hasta una distancia máxima de 8 metros. A diferencia de los sistemas tradicionales en los que las boquillas se deben colocar arriba, Comfort Air® permite una libre colocación de las boquillas, con indudables ventajas estéticas.

### **CONTROLLO TOTALE DELLA DIFFUSIONE DELL'ARIA**

Grazie ai due ventilatori indipendenti regolabili elettronicamente (nelle stufe a pellet) e alla centralina elettronica che può comandare fino a due canalizzazioni (nei termocamini), Comfort Air® consente un preciso controllo della diffusione del calore tra i vari ambienti dove l'aria viene canalizzata.

### **TOTAL AIR DISTRIBUTION CONTROL**

Fitting an electronic control unit, Comfort Air® can control up to two air flows (in closed fireplaces) to distribute heat and convey warm air into various rooms.

### **CONTRÔLE TOTAL DE LA DIFFUSION DE L'AIR**

Grâce à la centrale électronique pouvant commander jusqu'à deux ventilateurs (sur des foyers fermés), Comfort Air® permet un contrôle précis de la diffusion de la chaleur dans les différentes pièces.

### **VOLLE KONTROLLE DER LUFTVERTEILUNG**

Durch die Elektronik für die Steuerung von bis zu zwei Heißluftkanälen (in den Heizkaminen) ermöglicht Comfort Air® eine präzise Kontrolle der Wärmeverteilung in den verschiedenen Räumen, denen die Luft zugeführt wird.

### **CONTROL TOTAL DE LA DIFUSIÓN DE AIRE**

Gracias a la centralita electrónica que puede controlar hasta dos canalizaciones (en las chimeneas), Comfort Air® permite controlar de forma precisa la difusión del calor entre los diversos ambientes en los que se canaliza el aire.



### **FACILITÀ DI INSTALLAZIONE E MANUTENZIONE**

Grazie all'utilizzo di diametri sensibilmente inferiori (60mm e 100mm) rispetto al mercato, Comfort Air® garantisce un più facile inserimento della canalizzazione a parete, limitando gli interventi murari, spesso lunghi e invasivi, e una più facile manutenzione dei ventilatori.

### **EASE OF INSTALLATION AND MAINTENANCE**

With a significantly smaller diameter than other models on the market (60 mm and 100 mm), Comfort Air® ensures easier installation of the funnel into the wall, consequently limiting the necessary masonry works, which often take time and are very invasive, and making the fans easier to maintain.

### **SIMPLICITE D'INSTALLATION ET D'ENTRETIEN**

Grâce à des diamètres sensiblement plus petits (60 mm et 100 mm) par rapport à ceux du marché, le conduit Comfort Air® est plus facile à encastrer dans le mur, limite les travaux de maçonnerie souvent envahissants et qui demandent beaucoup de temps et facilite les opérations d'entretien des ventilateurs.

### **EINFACHE INSTALLATION UND WARTUNG**

Dank der deutlich geringeren Durchmesser (60 mm und 100 mm) als der am Markt gängigen Systeme, garantiert Comfort Air® eine leichte Wandinstallation der Kanalisierung, wobei zeit- und arbeitsaufwändige Baumaßnahmen erspart bleiben und eine einfache Wartung der Gebläse gewährleistet werden kann.

### **FACILIDAD DE INSTALACIÓN Y MANTENIMIENTO**

Gracias al uso de diámetros bastante inferiores (60 mm y 100 mm) respecto al mercado, Comfort Air® garantiza una inserción más fácil de la canalización en la pared, limitando los intervenciones murales, con frecuencia largas e invasivas, y un mantenimiento más fácil de los ventiladores.

### **I PRIMI DIFFUSORI DI DESIGN**

Comfort Air® è proposto con delle bocchette di diffusione dell'aria che, per la prima volta, sono un vero oggetto di design, perfettamente integrabili in qualsiasi arredamento grazie ad un design minimale e all'esclusiva funzione di illuminazione e aromaterapia che le rende uniche sul mercato.

### **THE FIRST DESIGN DIFFUSERS**

Comfort Air® is fitted with air distribution outlets that, for the first time, offer a true design piece. These outlets are ideal for integration into any furnishing, with their minimalist design and exclusive light and aromatherapy function that makes them unique on the market.

### **LES PREMIERS DIFFUSEURS DE DESIGN**

Comfort Air® est composé de bouches de diffusion de l'air qui, pour la première fois, constituent un véritable objet de design. Elles s'intègrent parfaitement à tous les types de meubles grâce à une apparence épurée et ses fonctions d'éclairage et d'aromathérapie sont uniques sur le marché.

### **DIE ERSTEN DESIGNERLUFTVERTEILER**

Comfort Air® ist mit Luftverteilern ausgestattet, die zum ersten Mal zu regelrechten Designobjekten werden: Dank ihrer minimalistisch gehaltenen Linienführung und ihrer exklusiven Beleuchtungs- und Aromatherapiefunktion, die sie einzigartig auf dem Markt machen, können sie sich jedem Wohnstil perfekt angepasst werden.

### **LOS PRIMEROS DIFUSORES DE DISEÑO**

Comfort Air® se propone con boquillas difusoras de aire que, por primera vez, son un auténtico objeto de diseño, perfectamente integrables en cualquier entorno gracias a un diseño mínimo y a la función exclusiva de iluminación y aromaterapia, siendo así únicas en el mercado.



**ventilazione forzata**  
**forced ventilation**  
**ventilation forcée**  
**zwangsbelüftung**  
**ventilación forzada**

Per riscaldare velocemente un ambiente o una zona della casa, con tutta la comodità della programmazione.

To heat quickly a room or an area of the home, with the full convenience of programming.

Pour réchauffer rapidement une pièce ou une zone de la maison, avec toute le confort de la programmation.

Um einen Raum oder Bereich des Hauses mit der bequemen Programmierung schnell zu heizen.

Para calentar rápidamente un ambiente o una zona de la casa, con toda la comodidad de la programación.



**convezione naturale**  
**convection versions**  
**convection naturelle**  
**natürlicher Konvektion**  
**convección natural**

A differenza delle normali stufe a pellet dotate di ventilazione forzata, qui il calore si diffonde in modo naturale per convezione. Ogni dettaglio tecnico è studiato per scambiare tutto il calore nell'ambiente.

Unlike a normal pellet stoves with forced ventilation, here the heat is diffused in a natural way via convection. Every technical detail has been designed to exchange all the heat in the room.

À la différence des poêles à pellets normaux dotés de ventilation forcée, ici la chaleur se diffuse de façon naturelle par convection. Chaque détail technique est étudié pour faire circuler toute la chaleur dans la pièce.

Im Gegensatz zu den herkömmlichen Pelletöfen mit Zwangsbelüftung verteilt sich die Wärme hier auf natürliche Weise mittels Konvektion. Jedes technische Detail wurde so entwickelt, dass die gesamte Wärme im Raum ausgetauscht wird.

A diferencia de las estufas normales de pellet dotadas de ventilación forzada, aquí el calor se difunde de forma natural mediante convección. Todos los detalles técnicos han sido estudiados para intercambiar todo el calor en el ambiente.



**acqua**  
**water**  
**eau**  
**wasserführende**  
**agua**

**TERMOSIFONI SUBITO CALDI**

Grazie ad una bassa inerzia termica le stufe a pellet Hydro, una volta accese, sono in grado di riscaldare i termosifoni di casa tua in pochi minuti (per alcuni modelli sono disponibili anche i kit di collegamento al circuito dell'acqua sanitaria).

**HOT RADIATORS FAST**

Thanks to low thermal inertia, Hydro pellet stoves, once on, are able to heat your domestic radiators in just a few minutes (for some models there are also kits for connection to the hot water system).

**RADIATEURS IMMÉDIATEMENT CHAUDS**

Grâce à une faible inertie thermique, les poêles à pellet Hydro, une fois qu'ils sont allumés, sont en mesure de chauffer les radiateurs de votre maison en quelques minutes (pour certains modèles, disponibilité des kits de raccordement au circuit de l'eau sanitaire).

**SOFORT WARMHEIT HEIZKÖRPER**

Dank einer geringen Wärmehaltigkeit können die Pelletöfen Hydro nach dem Einschalten die Heizkörper im Haus in wenigen Minuten wärmen (für einige Modelle sind auch Bausätze für den Anschluss an den Brauchwasserkreislauf erhältlich).

**RADIADORES CALIENTES ENSEGUIDA**

Gracias a una baja inercia térmica, las estufas Hydro, una vez encendidas, pueden calentar los radiadores de tu casa en pocos minutos (para algunos modelos también hay disponibles kits de conexión al circuito de agua sanitaria).



**acqua/aria**  
**water/air**  
**eau/air**  
**Wasser/Luft**  
**agua/aire**

**MASSIMO SCAMBIO TERMICO**

Circa il 90% della potenza resa globale della stufa viene trasferito all'acqua garantendo un'ottima performance per chi sceglie i termosifoni per scaldare la casa.

**MAXIMUM HEAT EXCHANGE**

About 90% of power rendered overall by the stove is transferred to the water guaranteeing excellent performance who those choosing radiators for domestic heating.

**ÉCHANGE THERMIQUE MAXIMAL**

Environ 90% de la puissance globale du poêle est transférée à l'eau en garantissant une performance optimale pour ceux qui choisissent les radiateurs pour chauffer leur maison.

**MAXIMALER WÄRMETAUSCH**

Zirka 90% der Gesamtleistung des Heizofens wird an das Wasser übertragen, so wird jedem, der Heizkörper für das Heizen seines Hauses wählt, eine optimale Leistung garantiert.

**MÁXIMO INTERCAMBIO TÉRMICO**

Aproximadamente el 90% de la potencia suministrada global de la estufa se transfiere al agua, garantizando un óptimo rendimiento para quien escoge los radiadores en la calefacción del hogar.

La tecnologia HYDRO-AIR consente di riscaldare sia l'ambiente in cui è installata la stufa, tramite ventilazione forzata, sia l'acqua dei termosifoni. La gestione della potenza all'aria è completamente controllabile dall'utente.

HYDRO-AIR technology allows to heat both the room in which the stove is installed, via forced ventilation, as well as the water in the radiators. The management of the air power can be fully controlled by the user.

La technologie HYDRO-AIR permettent de chauffer aussi bien l'espace où le poêle est installé, grâce à la ventilation forcée, que l'eau des radiateurs. À la différence des produits à eau traditionnels, l'utilisateur peut contrôler complètement la puissance de l'air.

HYDRO-AIR Technologie ermöglichen sowohl das Heizen des Raums, in dem der Kaminofen aufgestellt ist, durch Zwangsbelüftung als auch das Erhitzen des Wassers der Heizkörper. Kann die Raumleistung vollständig vom Benutzer gesteuert werden.

Tecnología HYDRO-AIR permiten calentar tanto el ambiente donde está instalada la estufa, mediante ventilación forzada, como el agua de los termosifones. La gestión de la potencia del aire puede ser controlada completamente por el usuario.



# Hydromatic: una nuova rivoluzione

**HYDROMATIC: A NEW REVOLUTION.**  
**HYDROMATIC : UNE NOUVELLE RÉVOLUTION.**  
**HYDROMATIC: EINE NEUE REVOLUTION.**  
**HYDROMATIC: UNA NUEVA REVOLUCIÓN.**

Evolute e migliorate, le nuove versioni Hydromatic sono frutto di severi test durati anni. Le soluzioni tecnologiche adottate in questi prodotti li rendono particolarmente performanti, affidabili e facili nell'utilizzo quotidiano.

Advanced and improved, the new Hydromatic versions are the result of strict testing that took years. The technological solutions implemented in these products make them especially high-performing, reliable and easy for every-day use.

Développées et améliorées, les nouvelles versions Hydromatic sont le résultat de tests rigoureux effectués sur plusieurs années. Les solutions technologiques adoptées pour ces produits les rendent particulièrement performants, fiables et simples d'utilisation chaque jour.

Fortschrittlich und verbessert, so sind die neuen Hydromatic-Versionen das Ergebnis harter und jahrelanger Prüfungen. Durch die angenommenen technischen Lösungen sind diese Produkte besonders leistungsstark, zuverlässig und beim täglichen Gebrauch leicht zu benutzen.

Desarrolladas y mejoradas, las nuevas versiones Hydromatic son el fruto de pruebas estrictas que han durado años. Las soluciones tecnológicas adoptadas en estos productos han procurado un gran rendimiento, fiabilidad y facilidad en el uso cotidiano.



## BRACIERE AUTOPULENTE

- \_Self-cleaning brazier
- \_Brasier autonettoyant
- \_Selbstreinigende Brennschale
- \_Brasero autolimpiador

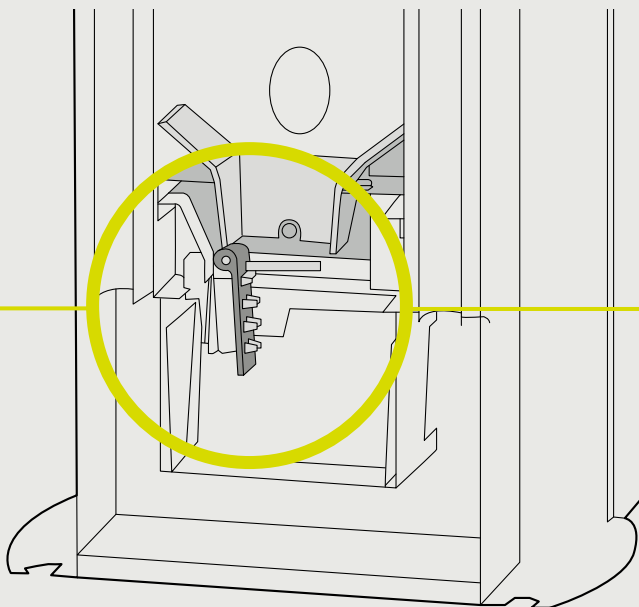

## FASCIO TUBIERO IN ACCIAIO INOX PER VENTILAZIONE FRONTALE

- \_Shell and tube in stainless steel for front ventilation
- \_Faisceaux de tubes en acier inox pour une ventilation frontale
- \_Rohrbündel aus edelstahl für frontbelüftung
- \_Haz de tubos de acero inoxidable para ventilación frontal



## ACCENSIONE IN 3 MINUTI

- \_Ignition in 3 minutes
- \_Allumage en 3 minutes
- \_Einschaltung in 3 Minuten
- \_Encendido en 3 minutos

## COMODO AZIONAMENTO DEI TURBOLATORI DAL VANO SERBATOIO

- \_Convenient turbulator operation from the tank compartment
- \_Actionnement facilité des turboloteurs à partir du compartiment réservoir
- \_Bequeme bedienung der turbolotoren aus dem behälterfach
- \_Accionamiento cómodo de los turbuladores del compartimiento del depósito

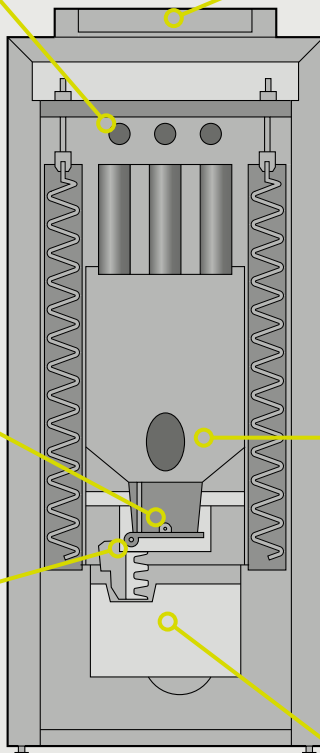

## LIVELLI DI PERFORMANCE PARTICOLARMENTE RILEVANTI

95,5%

- \_Higher performing
- \_Plus performants
- \_Effizientere Leistung
- \_Con altos rendimientos



## SVUOTAMENTO CENERE SETTIMANALE

- \_Weekly ash emptying
- \_Vidage des cendres hebdomadaire
- \_Wöchentliche Aschenentleerung
- \_Vaciado de las cenizas semanal

# Gamma completa /Full range /Gamme complète /Komplette Linie /Gama completa



**Versioni a convezione naturale o a ventilazione escludibile**  
**Natural convection or bypassed ventilation versions**  
**Versions à convection naturelle ou à ventilation pouvant être exclue**  
**Version mit natürlicher Konvektion oder ausschließbarer Lüftung**  
**Versiones con convección natural o con ventilación con posibilidad de exclusión**



**Versioni a ventilazione forzata**  
**Forced ventilation versions**  
**Versions à ventilation forcée**  
**Ausführungen mit zwangsbelüftung**  
**Versiones de ventilación forzada**





**Versioni ad aria canalizzata**  
**Ducted air versions**  
**Versions à air canalisé**  
**Ausführungen mit luftverteilung**  
**Versiones de aire canalizado**



**EGO** 10 kW p. 52 / 161  
**STAR** 10 kW p. 54 / 157  
**SUITE** 12 kW p. 60 / 158  
**CLUB** 12 kW p. 64 / 159  
**MUSA** 12/14 kW p. 68 / 160  
**AIKE** 8 kW p. 30 / 155  
**KLIN** 8 kW p. 38 / 154  
**TILDA** 10,1 kW p. 34 / 154  
**STREAM** 12,1 kW p. 98 / 168  
**FLAT** 8 kW p. 108 / 167



**FLAIR** 8 kW p. 106 / 167  
**PHILO** 9 kW p. 102 / 168  
**MAGGIE** 10,1 kW p. 88 / 164  
**TOBA** 8 kW p. 74 / 153  
**TUBE** 8 kW p. 72 / 166  
**NIMA** 11,5 kW p. 78 / 166  
**MOOD** 8 kW p. 24 / 152  
**CURVE** 8 kW p. 20 / 152  
**VIVO 80** 10,5 kW p. 144  
**VIVO 90** 10,5 kW p. 132 / 142



**Versioni ad acqua e aria/acqua**  
**Hydro and air/hydro versions**  
**Versions hydro et air/hydro**  
**Hydro und Air/Hydro Ausführungen**  
**Versiones a agua y aire/agua**



**EGO HYDRO** 11,6 kW p. 116 / 170  
**STAR HYDRO** 11,6 kW p. 118 / 171  
**MUSA HYDRO** 15,4/22,3 kW p. 120 / 171  
**SUITE HYDRO** 15,4/22,3 kW p. 122 / 172  
**CLUB HYDRO** 15,4/22,3 kW p. 124 / 172  
**MUSA** 16/24 kW p. 68 / 160  
**SUITE** 16/24 kW p. 60 / 158  
**CLUB** 16/24 kW p. 64 / 159  
**FLUX** 16 kW p. 114 / 169  
**TOBA** 22,3 kW p. 74 / 153  
**SWING** 24,8 kW p. 110 / 170  
**DUO** 22,3 kW p. 126 / 169  
**VIVO 80** 16,7 kW(14kW) p. 146  
**VIVO 85** 22,3 kW p. 128 / 148



# Curve

/Comfort Air 8

Technical Data > p. 152



\_Stufa a pellet senza bocchette frontali realizzata con rivestimento in ceramica colorata (White, Warm Grey, Bordeaux, Black) e particolarmente adatta per una collocazione ad angolo. Nuovo focolare dalle linee adolcite, più ampio e profondo per una migliore visione del fuoco. Prodotto equipaggiato con candeletta in ceramica che garantisce dei tempi di accensione ridotti del 40%. Di serie il telecomando con funzione termostato ambiente.

\_Pellet stove without front vents, with coloured ceramic cladding (White, Warm Grey, Bordeaux, Black) and particularly suitable for corner installation. The new firebox, featuring curved lines, is larger and deeper allowing a better view of the fire. Product equipped with ceramic spark plug ensuring ignition times reduced by 40%. Remote control with room thermostat as standard.

\_Poêle à pellets sans bouches frontales, réalisé avec un revêtement en céramique coloré (White, Warm Grey, Bordeaux, Black) et particulièrement adapté pour une installation d'angle. Nouveau foyer aux lignes adoucies, plus large et profond pour une meilleure vision du feu. Produit équipé d'une bougie d'allumage en céramique qui garantit des temps d'allumage réduits de 40%. De série la télécommande avec fonction thermostat d'ambiance.

\_Pelletofen ohne frontale Luftöffnungen mit Verkleidung aus farbiger Keramik (White, Warm Grey, Bordeaux, Black) und besonders geeignet zum Aufstellen in einer Ecke. Ein neuer Feuerraum mit weniger strengen Linien, größer und tiefer, vltzeiten gewährleistet, ausgestattetes Produkt. Serienmäßig die Fernbedienung mit Raumthermostatfunktion.

Estufa de pellet sin orificios frontales realizada con revestimiento de cerámica de color (White, Warm Grey, Bordeaux, Black) y muy adecuada para instalaciones en esquinas. Nuevo hogar de líneas suaves, más amplio y profundo para mejorar la visión del fuego. Producto equipado con bujía de cerámica que garantiza tiempos de encendido reducidos un 40%. De serie el mando a distancia con función de termostato ambiente.

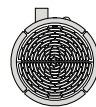
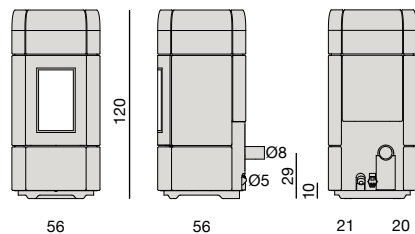







# Mood

/Comfort Air 8

Technical Data > p. 152



\_Stufa a pellet di forma rotonda e dal design minimale, grazie all'assenza di bocchette frontali. Adatta per una collocazione ad angolo, ha top in alluminio verniciato nero e fianchi in acciaio color Bronze, Silver e Black. Nuovo focolare dalle linee addolcite, più ampio e profondo per una migliore visione del fuoco. Prodotto equipaggiato con candelletta in ceramica che garantisce dei tempi di accensione ridotti del 40%. Di serie il telecomando con funzione termostato ambiente.

\_Round pellet stove with minimalist design, thanks to the absence of front vents. Suitable for corner installation, with top in black coated aluminium and steel sides in the colours Bronze, Silver and Black. The new firebox, featuring curved lines, is larger and deeper allowing a better view of the fire. Product equipped with ceramic spark plug ensuring ignition times reduced by 40%. Remote control with room thermostat as standard.

\_Poêle à pellets de forme ronde et au design minimaliste grâce à l'absence de bouches frontales. Adapté pour une installation d'angle, il présente un couvercle en aluminium peint noir et des cotés en acier couleur Bronze, Silver et Black. Nouveau foyer aux lignes adoucies, plus large et profond pour une meilleure vision du feu. Produit équipé d'une bougie d'allumage en céramique qui garantit des temps d'allumage réduits de 40%. De série la télécommande avec fonction thermostat d'ambiance.

\_Pelletofen mit runder Form und minimalistischem Design, dank dem Fehlen frontaler Luftöffnungen. Der Ofen ist zum Aufstellen in einer Ecke geeignet und hat eine Top-Platte aus schwarz lackiertem Aluminium und Seitenwände aus Stahl in den Farben Bronze, Silver und Black. Ein neuer Feuer-raum mit weniger strengen Linien, größer und tiefer, für eine bessere Sicht auf das Feuer. Mit einer Keramikzündkerze, die um 40% reduzierte Einschaltzeiten gewährleistet, ausgestattet Produkt. Serienmäßig die Fernbedienung mit Raumthermostatfunktion.

\_Estufa de pellet de forma redonda y con un diseño minimalista, gracias a la ausencia de orificios frontales. Adecuada para instalaciones en esquinas, con encimera de aluminio pintado negro y laterales de acero de color Bronze, Silver y Black. Nuevo hogar de líneas suaves, más amplio y profundo para mejorar la visión del fuego. Producto equipado con bujía de cerámica que garantiza tiempos de encendido reducidos un 40%. De serie el mando a distancia con función de termostato ambiente.

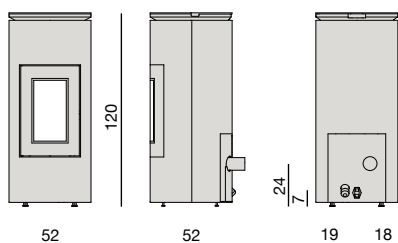



\_Stufa a pellet senza bocchette frontali realizzata in acciaio nero e pannello frontale colorato (Aluminium, Silver, Dark, Bordeaux). Particolarmente indicata per una collocazione ad angolo. Nuovo focolare dalle linee addolcite, più ampio e profondo per una migliore visione del fuoco. Prodotto equipaggiato con candeletta in ceramica che garantisce dei tempi di accensione ridotti del 40%. Di serie il telecomando con funzione termostato ambiente.

\_Pellet stove with no front vents, made in black steel with a coloured front panel (Aluminium, Silver, Dark, Bordeaux). Particularly suitable for corner installation. The new firebox, featuring curved lines, is larger and deeper allowing a better view of the fire. Product equipped with ceramic spark plug ensuring ignition times reduced by 40%. Remote control with room thermostat as standard.

\_Poêle à pellets sans bouches frontales, réalisé en acier noir et panneau frontal coloré (Aluminium, Silver, Dark, Bordeaux). Particulièrement indiqué pour une installation d'angle. Nouveau foyer aux lignes adoucies, plus large et profond pour une meilleure vision du feu. Produit équipé d'une bougie d'allumage en céramique qui garantit des temps d'allumage réduits de 40%. De série la télécommande avec fonction thermostat d'ambiance.

\_Pelletofen ohne frontale Luftöffnungen aus schwarzem Stahl und mit farbiger Vorderplatte (Aluminium, Silver, Dark, Bordeaux). Besonders geeignet zum Aufstellen in einer Ecke. Ein neuer Feuer- raum mit weniger strengen Linien, größer und tiefer, für eine bessere Sicht auf das Feuer. Mit einer Keramikzündkerze, die um 40% reduzierte Einschaltzeiten gewährleistet, ausgestattetes Produkt. Serienmäßig die Fernbedienung mit Raumthermo- statfunktion.

\_Estufa de pellet sin orificios frontales de acero negro y panel frontal de color (Aluminium, Silver, Dark, Bordeaux). Muy indicada para instalaciones en esquinas. Nuevo hogar de líneas suaves, más amplio y profundo para mejorar la visión del fuego. Producto equipado con bujía de cerámica que garantiza tiempos de encendido reducidos un 40%. De serie el mando a distancia con función de termostato ambiente.

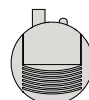
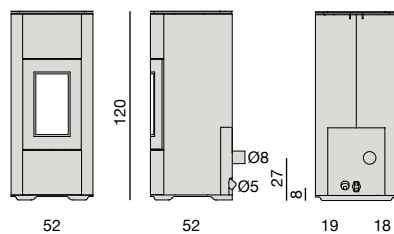

# Halo

/Air 8

Technical Data > p. 153





# Aike

/Air Oyster 8 /Comfort Air 8

Technical Data > p. 155





\_Stufa a pellet senza bocchette frontali realizzata con struttura interamente in acciaio verniciato. Di serie il telecomando con funzione termostato ambiente. Grazie alla tecnologia Oyster che rende la struttura perfettamente stagna, può essere collocata all'interno di tutte le case ben isolate e all'interno delle case passive.

\_Pellet stove with no front vents, made with a structure entirely made of painted steel. Remote control with room thermostat as standard. With its Oyster technology, which ensures the product is 100% airtight, it can be placed in all well-insulated houses and in passive houses.

\_Poêle à pellets sans bouche frontale, réalisé grâce à une structure entièrement en acier peint. De série la télécommande avec fonction thermostat d'ambiance. Grâce à la technologie Oyster qui rend la structure parfaitement étanche, il peut être placé à l'intérieur de toutes les maisons bien isolées et à l'intérieur des maisons passives.

\_Pelletofen ohne frontale Luftöffnungen mit Korpus komplett aus lackiertem Stahl. Serienmäßig die Fernbedienung mit Raumthermostatfunktion. Dank der Oyster-Technologie, durch die der Korpus völlig abgedichtet wird, kann er in allen gut gedämmten Häusern und Passivhäusern aufgestellt werden.

\_Estufa de pellet sin bocas frontales, realizada con estructura completamente de acero pintado. De serie el mando a distancia con función de termostato ambiente. Gracias a la tecnología Oyster, que hace que la estructura perfectamente estanca, se puede colocar dentro de todas las casas bien aisladas y dentro de las casas pasivas.

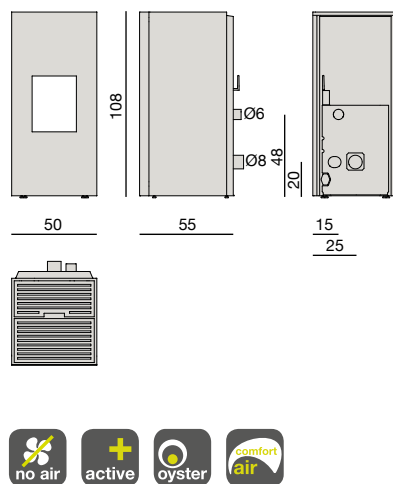





# Tilda

/Comfort Air 10

Technical Data > p. 154



\_Stufa a pellet senza bocchette frontali realizzata con struttura in acciaio verniciato, porta frontale in vetro. Di serie il telecomando con funzione termostato ambiente. Dotata di due ventilatori regolabili in modo indipendente tramite telecomando.

\_Pellet stove with no front vents, made with a painted steel structure, glass front door. Remote control with room thermostat as standard. Fitted with two fans that can be set separately with a remote control.

\_Poêle à pellets sans bouche frontale, réalisé grâce à une structure en acier peint, porte frontale en verre. De série la télécommande avec fonction thermostat d'ambiance. Équipé de deux ventilateurs réglables de manière indépendante au moyen d'une télécommande.

\_Pelletofen ohne frontale Luftöffnungen mit Korpus aus lackiertem Stahl und vorderer Glastür. Serienmäßig die Fernbedienung mit Raumthermostatfunktion. Mit zwei Ventilatoren, die mit einer Fernbedienung unabhängig voneinander eingestellt werden können.

\_Estufa de pellet sin bocas frontales realizada con estructura de acero pintado, y puerta frontal de cristal. De serie el mando a distancia con función de termostato ambiente. Tiene dos ventiladores regulables de forma independiente con el mando a distancia.

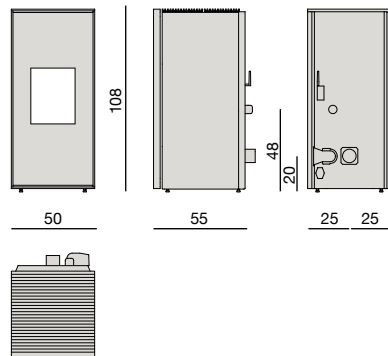





# Klin

/Comfort Air 8

Technical Data > p. 154





\_Stufa a pellet senza bocchette frontali realizzata con struttura in acciaio verniciato, porta frontale in vetro e fianchi laterali in serpentino o acciaio verniciato. Di serie il telecomando con funzione termostato ambiente. Dotata di due ventilatori regolabili in modo indipendente tramite telecomando.

\_Pellet stove with no front vents, made with a painted steel structure, glass front door and serpentine stone or painted steel side panels. Remote control with room thermostat as standard. Fitted with two fans that can be set separately with a remote control.

\_Poêle à pellets sans bouche frontale, réalisé grâce à une structure en acier peint, porte frontale en verre et flancs latéraux en pierre serpentine ou en acier peint. De série télécommande avec fonction thermostat d'ambiance. Équipé de deux ventilateurs réglables de manière indépendante au moyen d'une télécommande.

\_Pelletofen ohne frontale Luftöffnungen mit Korpus aus lackiertem Stahl, vorderer Glastür und Seitenwänden aus Serpentin oder lackiertem Stahl. Serienmäßig die Fernbedienung mit Raumthermostatfunktion. Mit zwei Ventilatoren, die mit einer Fernbedienung unabhängig voneinander eingestellt werden können.

\_Estufa de pellet sin bocas frontales, realizada con estructura de acero pintado, puerta frontal de cristal y costados en serpentin o acero pintado. De serie el mando a distancia con función de termostato ambiente. Tiene dos ventiladores regulables de forma independiente con el mando a distancia.

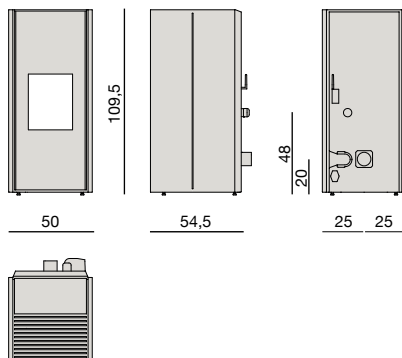





# Lam

/Natural 8

Technical Data > p. 156



\_Stufa a pellet a convezione naturale con tecnologia Still, realizzata con struttura in acciaio, top in alluminio nero e fianchi in tessuto metallico traforato, in acciaio o in pietra. Braciere e focolare in ghisa. Stufa equipaggiabile con sistema di canalizzazione dell'aria Comfort Air (kit opzionale). Di serie il telecomando con funzione termostato ambiente.

\_Natural convection pellet stove with Still technology made with a steel structure, black aluminium top and sides made with perforated metallic fabric, steel or stone. Cast iron brazier and firebox. Stove that can be fitted with a Comfort Air air ducting system (optional kit). Remote control with room thermostat as standard.

\_Poêle à pellet à convection naturelle exploitant la technologie Still, réalisé avec une structure en acier, un couvercle en aluminium noir et des flancs en tissu métallique perforé, en acier ou en pierre. Braserio et foyer en fonte. Il est possible de l'équiper avec un système de canalisation de l'air Comfort Air (kit en option). De série la télécommande avec fonction thermostat d'ambiance.

\_Pelletofen mit natürlicher Konvektion und Still-Technologie. Mit Stahlkorpus, Top aus schwarzem Aluminium und Außenseiten aus gelochtem Metallgewebe, Stahl oder Stein. Brennschale und Feuerraum aus Gusseisen. Der Kaminofen kann durch das Comfort Air System zur Luftkanalisation ergänzt werden. Serienmäßig die Fernbedienung mit Raumthermostatfunktion.

\_Estufa de pellet de convección natural con tecnología Still, realizada con estructura de acero, parte superior de aluminio negro y laterales en tejido metálico perforado, de acero o piedra. Braserio y hogar de fundición. Estufa que puede equiparse con sistema de canalización del aire Comfort Air (kit opcional). De serie el mando a distancia con función de termostato ambiente.

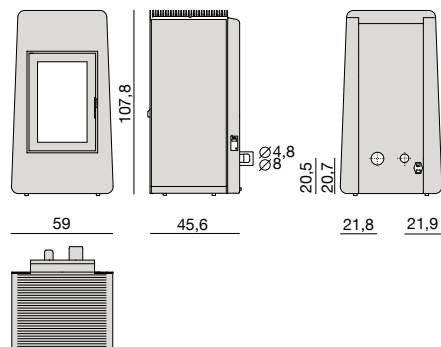



# Cap

/Natural 8

Technical Data > p. 156



\_Stufa a pellet dal design minimale, grazie all'assenza di bocchette frontali; ha una griglia superiore in alluminio, struttura in acciaio verniciata in bi-colore Black – Bronze. Braciere e focolare in ghisa. Stufa equipaggiabile con sistema di canalizzazione dell'aria Comfort Air (kit opzionale). Di serie il telecomando con funzione termostato ambiente. Di serie il telecomando con funzione termostato ambiente.

\_Pellet-fuelled stove with a minimal design, thanks to the fact that there are no front outlets. It is fitted with an upper aluminium grid and a two-coloured Black – Bronze painted steel structure. Cast iron brazier and firebox. Stove that can be fitted with a Comfort Air air ducting system (optional kit). Remote control with room thermostat as standard. Remote control with room thermostat as standard.

\_Poêle à pellets au design minimaliste grâce à l'absence de bouches frontales ; il possède une grille supérieure en aluminium, une structure en acier laqué bicolore coloris noir et bronze. Brasero et foyer en fonte. Il est possible de l'équiper avec un système de canalisation de l'air Comfort Air (kit en option). De série la télécommande avec fonction thermostat d'ambiance. De série la télécommande avec fonction thermostat d'ambiance.

\_Elektrischer Ofen und Pelletofen von minimalistischem Design dank der Abwesenheit der Düsen an der Stirnseite; Gitter aus Aluminium, eine Struktur aus lackiertem Stahl in zwei Farben Black – Bronze. Brennschale und Feuerraum aus Gusseisen. Der Kaminofen kann durch das Comfort Air System zur Luftkanalisation ergänzt werden. Serienmäßig die Fernbedienung mit Raumthermostatfunktion. Serienmäßig die Fernbedienung mit Raumthermostatfunktion.

\_Estufa de pellet de diseño minimalista, gracias a la ausencia de boquillas frontales; tiene una rejilla superior de aluminio, estructura de acero pintado en bi-color Negro- Bronze. Brasero y hogar de fundición. Estufa que puede equiparse con sistema de canalización del aire Comfort Air (kit opcional). De serie el mando a distancia con función de termostato ambiente.

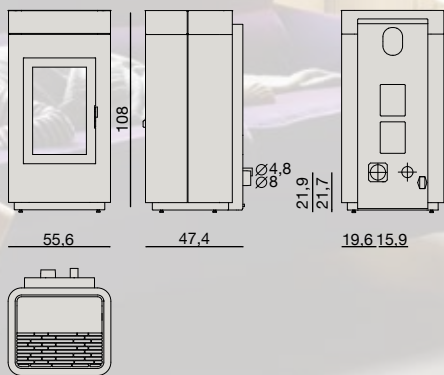





# Tray

/Natural 8

Technical Data > p. 157



\_Stufa a pellet dal design minimale, grazie all'assenza di bocchette frontali; ha una griglia superiore in alluminio, fianchi in acciaio verniciato color Black e Bronze. Braciere e focolare in ghisa. Stufa equipaggiabile con sistema di canalizzazione dell'aria Comfort Air (kit opzionale). Di serie il telecomando con funzione termostato ambiente.

\_Pellet-fuelled stove with a minimal design, thanks to the fact that there are no front outlets. It is fitted with an upper aluminium grid and Black and Bronze painted steel side panels. Cast iron brazier and firebox. Stove that can be fitted with a Comfort Air air ducting system (optional kit). Remote control with room thermostat as standard.

\_Poêle à pellets au design minimaliste grâce à l'absence de bouches frontales ; il possède une grille supérieure en aluminium, des flancs en acier laqué coloris noir et bronze. Brasero et foyer en fonte. Il est possible de l'équiper avec un système de canalisation de l'air Comfort Air (kit en option). De série la télécommande avec fonction thermostat d'ambiance.

\_Ofen und Pelletofen von minimalistischem Design dank der Abwesenheit der Düsen an der Stirnseite; Gitter aus Aluminium, Seitenwände aus lackiertem Stahl Farbe Black und Bronze. Brennschale und Feuerraum aus Gusseisen. Der Kaminofen kann durch das Comfort Air System zur Luftkanalisation ergänzt werden. Serienmäßig die Fernbedienung mit Raumthermostatfunktion.

\_Estufa de pellet de diseño minimalista, gracias a la ausencia de boquillas frontales; tiene una rejilla superior de aluminio, estructura de acero pintado en bi-color Negro- Bronze. Brasero y hogar de fundición. Estufa que puede equiparse con sistema de canalización del aire Comfort Air (kit opcional). De serie el mando a distancia con función de termostato ambiente.

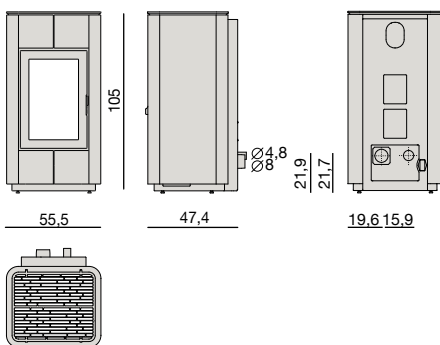



# Ego

/Air 8 /Air 8 Oyster /Comfort Air 10

Technical Data > p. 161



\_Stufa a pellet realizzata con struttura in acciaio, top in ghisa e fianchi in acciaio. Braciere in ghisa. Di serie e il telecomando con funzione termostato ambiente. La versione Comfort Air è dotata di due ventilatori regolabili in modo indipendente tramite telecomando. Disponibile nella versione con scarico superiore e nella versione stagna, con tecnologia Oyster.

\_Pellet stove made with a steel structure, cast iron top and steel sides. Cast iron brazier. Remote control with room thermostat as standard. The Comfort Air version has two fans that can be set separately with the remote control. Available in the version with top exhaust and in the airtight version, with Oyster technology.

\_Poêle à pellet réalisé avec une structure en acier, un couvercle en fonte et des flancs en acier. Brasero en fonte. De série la télécommande avec fonction thermostat d'ambiance. La version Comfort Air est dotée de deux ventilateurs réglables de manière indépendante avec la télécommande. Disponible dans la version avec déchargement sur la partie supérieure et dans la version étanche, avec la technologie Oyster.

\_Pelletofen mit Stahlkorpus, Top aus Gusseisen und Außenseiten aus Stahl. Brennschale aus Gusseisen. Serienmäßig die Fernbedienung mit Raumthermostatfunktion. Die Ausführung Comfort Air verfügt über zwei Ventilatoren, die mit einer Fernbedienung unabhängig voneinander eingestellt werden können. Erhältlich in der Version mit oberem Rauchabzug und in der dichten Version mit Oyster-Technologie.

\_Estufa de pellet realizada con estructura de acero, con la parte superior en fundición y los laterales de acero. Brasero de fundición. De serie, el mando a distancia con función de termostato ambiente. La versión Comfort Air tiene dos ventiladores regulables de forma independiente mediante el mando a distancia. Disponible en la versión con descarga superior y versión estanca, con tecnología Oyster.

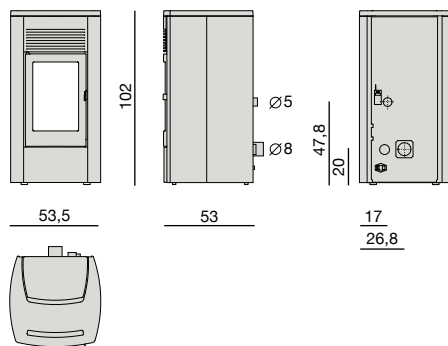



# Star

/Air 8/ Comfort Air 10

Technical Data > p. 157





\_Stufa a pellet realizzata con struttura in acciaio, top e fianchi in ceramica. Braciere in ghisa. Di serie il telecomando con funzione termostato ambiente. La versione Comfort Air è dotata di due ventilatori regolabili in modo indipendente tramite telecomando.

\_Pellet stove with steel structure, ceramic top and sides. Cast iron brazier. Remote control with room thermostat as standard. The Comfort Air version has two fans that can be set separately with the remote control.

\_Poêle à pellet réalisé avec une structure en acier, un couvercle et des flancs en céramique. Brasero en fonte. De série la télécommande avec fonction thermostat d'ambiance. La version Comfort Air est dotée de deux ventilateurs réglables de manière indépendante avec la télécommande.

\_Pelletofen mit Stahlkorpus, Top und Außenseiten aus Keramik. Brennschale aus Gusseisen. Serienmäßig der Ausschluss die Fernbedienung mit Raumthermostatsfunktion. Die Ausführung Comfort Air verfügt über zwei Ventilatoren, die mit einer Fernbedienung unabhängig voneinander eingestellt werden können.

\_Estufa de pellet realizada con estructura de acero, con la parte superior y los laterales en cerámica. Brasero de fundición. De serie el mando a distancia con función de termostato ambiente. La versión Comfort Air tiene dos ventiladores regulables de forma independiente mediante el mando a distancia.

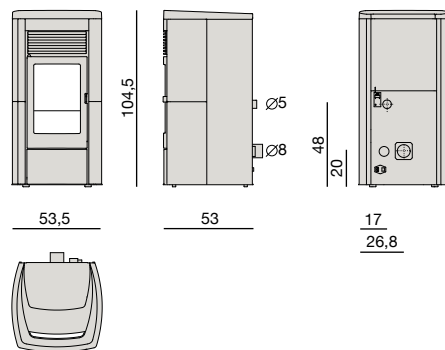



# Sagar

/Air 8

Technical Data > p. 155



\_Stufa a pellet realizzata in acciaio con top in ceramica neutra o decorata, oppure in pietra ollare, fianchi verniciati a polveri nero; il top è disponibile nei colori: white, decor, soapstone. Di serie il telecomando con funzione termostato ambiente.

\_Pellet stove made of steel with neutral or decorated ceramic top, or soapstone, black powder-coated sides; the top is available in three colors: white, decor, soapstone. Remote control with room thermostat as standard.

\_Poêle à pellet réalisé en acier avec dessus en céramique neutre ou décorée, ou bien en pierre ollaire, côtés peints en noir avec des poudres; le dessus est disponible dans les coloris: white, decor, soapstone. De série la télécommande avec fonction thermostat d'ambiance.

\_Pelletheizofen aus Stahl mit neutraler oder dekorierter Abdeckplatte oder Specksteinplatte, Außenseiten aus schwarzem pulverlackiertem Stahl; die Abdeckplatte ist in den Farben white, decor und soapstone lieferbar. Serienmäßig die Fernbedienung mit Raumthermostatfunktion.

\_Estufa de pellets realizada en acero con top de cerámica neutra o decorada, o bien de esteatita, lados pintados con polvo negro; el top está disponible en los colores: white, decor, soapstone. De serie el mando a distancia con función de termostato ambiente.

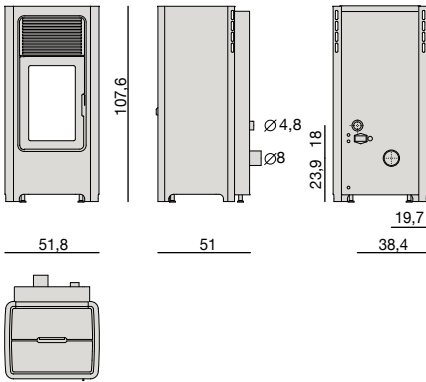



# Suite

/Air 10 /Comfort Air 12

/Hydromatic 16 / Hydromatic 24

Technical Data > p. 158



\_Stufa a pellet realizzata con struttura in acciaio, top e fianchi in ceramica. Braciere in ghisa. Di serie il telecomando con funzione termostato ambiente. La versione Comfort Air è dotata di due uscite posteriori e tre ventilatori regolabili in modo indipendente tramite telecomando. Nuova versione Hydromatic dotata di braciere autopulente con svuotamento cenere settimanale e manutenzione straordinaria semplificata.

\_Pellet stove with steel structure, ceramic top and sides. Cast iron brazier. Remote control with room thermostat as standard. The Comfort Air version has two outlets at the back and three fans that can be set separately with the remote control. New Hydromatic version, equipped with self-cleaning brazier, with weekly ash emptying and simplified special maintenance.

\_Poêle à pellet réalisé avec une structure en acier, un couvercle et des flancs en céramique. Brasero en fonte. De série, la télécommande avec fonction thermostat d'ambiance. La version Comfort Air est dotée de deux sorties postérieures et de trois ventilateurs réglables de manière indépendante avec la télécommande. Nouvelle version Hydromatic équipée d'un brasier autonettoyant avec vidage des cendres hebdomadaire et entretien extraordinaire simplifié.

\_Pelletofen mit Stahlkorpus, Top und Außenseiten aus Keramik. Brennschale aus Gusseisen. Serienmäßig der Ausschuss die Fernbedienung mit Raumthermostatfunktion. Die Ausführung Comfort Air verfügt über zwei hintere Auslässe und drei Ventilatoren, die mit einer Fernbedienung unabhängig voneinander eingestellt werden können. Neue Hydromatic-Version mit selbstreinigender Brennschale für eine wöchentliche Aschenentleerung und vereinfachter außerordentlicher Wartung.

\_Estufa de pellet realizada con estructura de acero, con la parte superior y los laterales en cerámica. Brasero de fundición. De serie, el mando a distancia con función de termostato ambiente. La versión Comfort Air tiene dos salidas traseras y tres ventiladores regulables de forma independiente mediante mando a distancia. Nueva versión Hydromatic provista de brasero autolimpiador con vaciado de cenizas semanal y mantenimiento extraordinario simplificado.

Air 10 / Comfort Air 12

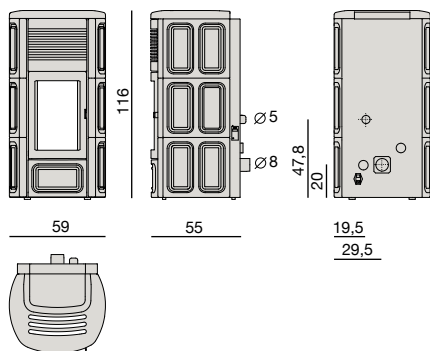

Hydromatic 16 / Hydromatic 24

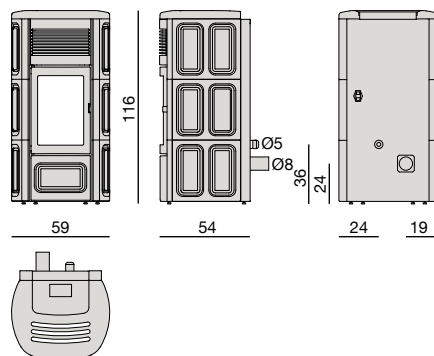







# Club

/Air 10 /Comfort Air 12

/Hydromatic 16 / Hydromatic 24

Technical Data > p. 159



\_Stufa a pellet realizzata con struttura in acciaio, top e fianchi in ceramica. Braciere in ghisa. Di serie il telecomando con funzione termostato ambiente. La versione Comfort Air è dotata di due uscite posteriori e tre ventilatori regolabili in modo indipendente tramite telecomando. Nuova versione Hydromatic dotata di braciere autopulente con svuotamento cenere settimanale e manutenzione straordinaria semplificata.

\_Pellet stove with steel structure, ceramic top and sides. Cast iron brazier. Remote control with room thermostat as standard. The Comfort Air version has two outlets at the back and three fans that can be set separately with the remote control. New Hydromatic version, equipped with self-cleaning brazier, with weekly ash emptying and simplified special maintenance.

\_Poêle à pellet réalisé avec une structure en acier, un couvercle et des flancs en céramique. Brasero en fonte. De série, la télécommande avec fonction thermostat d'ambiance. La version Comfort Air est dotée de deux sorties postérieures et de trois ventilateurs réglables de manière indépendante avec la télécommande. Nouvelle version Hydromatic équipée d'un brasier autonettoyant avec vidage des cendres hebdomadaire et entretien extraordinaire simplifié.

\_Pelletofen mit Stahlkorpus, Top und Außenseiten aus Keramik. Brennschale aus Gusseisen. Serienmäßig der Ausschuss die Fernbedienung mit Raumthermostatfunktion. Die Ausführung Comfort Air verfügt über zwei hintere Auslässe und drei Ventilatoren, die mit einer Fernbedienung unabhängig voneinander eingestellt werden können. Neue Hydromatic-Version mit selbstreinigender Brennschale für eine wöchentliche Aschenentleerung und vereinfachter außerordentlicher Wartung.

\_Estufa de pellet realizada con estructura de acero, con la parte superior y los laterales en cerámica. Brasero de fundición. De serie, el mando a distancia con función de termostato ambiente. La versión Comfort Air tiene dos salidas traseras y tres ventiladores regulables de forma independiente mediante mando a distancia. Nueva versión Hydromatic prevista de brasero autolimpiador con vaciado de cenizas semanal y mantenimiento extraordinario simplificado.

Air 10 / Comfort Air 12

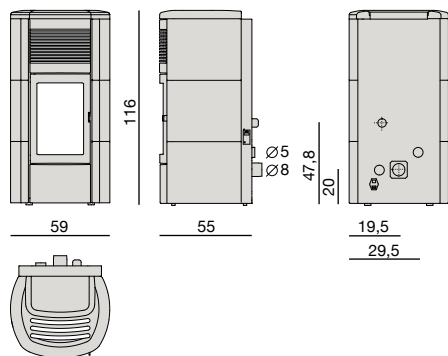

Hydromatic 16 / Hydromatic 24

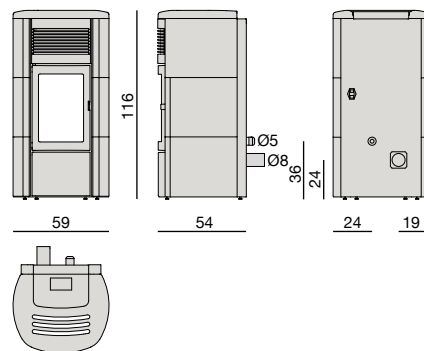





# Musa

/Air 10 /Comfort Air 12 /Comfort Air 14  
/Hydromatic 16 / Hydromatic 24

Technical Data > p. 160



\_Stufa a pellet realizzata con struttura in acciaio, top in ghisa e fianchi in acciaio. Braciere in ghisa. Di serie il telecomando con funzione termostato ambiente. La versione Comfort Air è dotata di due uscite posteriori e tre ventilatori regolabili in modo indipendente tramite telecomando. Nuova versione Hydromatic dotata di braciere autopulente con svuotamento cenere settimanale e manutenzione straordinaria semplificata.

\_Pellet stove made with a steel structure, cast iron top and steel sides. Cast iron brazier. Remote control with room thermostat as standard. The Comfort Air version has two outlets at the back and three fans that can be set separately with the remote control. New Hydromatic version, equipped with self-cleaning brazier, with weekly ash emptying and simplified special maintenance.

\_Poêle à pellet réalisé avec une structure en acier, un couvercle en fonte et des flancs en acier. Brasero en fonte. De série, la télécommande avec fonction thermostat d'ambiance. La version Comfort Air est dotée de deux sorties postérieures et de trois ventilateurs réglables de manière indépendante avec la télécommande. Nouvelle version Hydromatic équipée d'un brasier autonettoyant avec vidage des cendres hebdomadaire et entretien extraordinaire simplifié.

\_Pelletofen mit Stahlkorpus, Top aus Gusseisen und Außenseiten aus Stahl. Brennschale aus Gusseisen. Serienmäßig der Ausschluss die Fernbedienung mit Raumthermostاتفunktion. Die Ausführung Comfort Air verfügt über zwei hintere Auslässe und drei Ventilatoren, die mit einer Fernbedienung unabhängig voneinander eingestellt werden können. Neue Hydromatic-Version mit selbstreinigender Brennschale für eine wöchentliche Aschenentleerung und vereinfachter außerordentlicher Wartung.

\_Estufa de pellet realizada con estructura de acero, con la parte superior en fundición y los laterales de acero. Brasero de fundición. De serie, el mando a distancia con función de termostato ambiente. La versión Comfort Air tiene dos salidas traseras y tres ventiladores regulables de forma independiente mediante mando a distancia. Nueva versión Hydromatic provista de brasero autolimpiador con vaciado de cenizas semanal y mantenimiento extraordinario simplificado.

#### Air 10 / Comfort Air 12

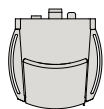
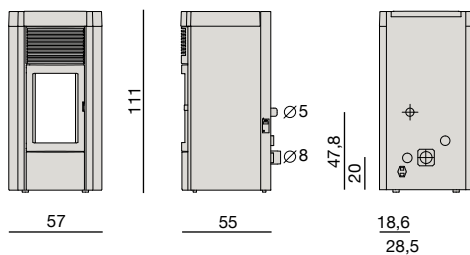

#### Hydromatic 16 / Hydromatic 24

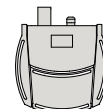
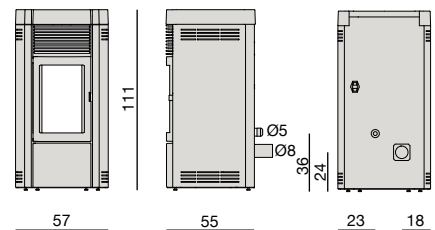





# Tube

/Comfort Air 8

Technical Data > p. 166



\_Stufa a pellet di forma rotonda e dal design minimale, grazie all'assenza di bocchette frontali; adatta per una collocazione ad angolo, ha top in alluminio verniciato nero e fianchi in acciaio color Bronze, Silver e Black. Di serie il telecomando con funzione termostato ambiente.

\_Round pellet stove featuring a minimal design, owing to the absence of any front hot air outlets; suitable for corner installation, with a black painted aluminium top and Bronze, Silver and Black steel sides. Remote control with room thermostat as standard.

\_Poêle à pellets de forme ronde et au design épuré, grâce à l'absence de bouches d'air frontales ; adapté à un placement en angle, il présente un dessus en aluminium peint en noir et des bords en acier Bronze, Silver et Black (noir). De série la télécommande avec fonction thermostat d'ambiance.

\_Pelletofen in runder Form und minimalistischem Design, dank des Fehlens von Düsen vorne; eignet sich zur Eckaufstellung; besitzt ein Top aus schwarz lackiertem Aluminium und Seitenteile aus Stahl in Bronze, Silver und Black. Serienmäßig die Fernbedienung mit Raumthermostatfunktion.

\_Estufa de pellet de forma redonda y de diseño minimalista, gracias a la ausencia de salidas frontales; adaptada para una colocación esquinada, tiene tapa de aluminio pintado en negro y lados de acero de color Bronze, Silver y Black (nigro). De serie el mando a distancia con función de termostato ambiente.

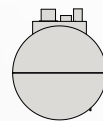
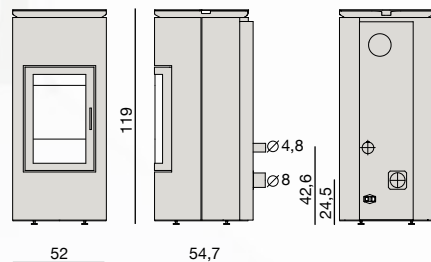



# Toba

/Air 8 /Comfort Air 8 /Hydro 22

Technical Data > p. 153



\_Stufa a pellet dal design minimale grazie all'assenza di bocchette frontali; realizzata in acciaio con frontale in ceramica colorata (White, Black, Bordeaux) o effetto cuoio (Skin) e in pietra (Sandstone, Soapstone). Di serie il telecomando con funzione termostato ambiente.

Pellet stove with a minimal design, thanks to the fact that there are no front outlets. Made of steel with in coloured ceramic (White, Black, Bordeaux) or leather effect (Skin) and stone finishes (Sandstone, Soapstone). Remote control with room thermostat as standard.

\_Poêle à pellets au design minimaliste grâce à l'absence de bouches d'air frontales ; il est réalisé en acier avec un panneau frontal en céramique colorée (White, Black, Bordeaux) ou effet cuir (Skin) et en pierre (Sandstone, Soapstone). De série la télécommande avec fonction thermostat d'ambiance.

\_Pelletofen, dem das Fehlen frontaler Luftöffnungen ein minimalistisches Design verleiht. Aus Stahl, mit der lackierten Keramik-Endbearbeitung (White, Black, Bordeaux) oder mit Ledereffekt (Skin) und aus Stein (Sandstone, Soapstone). Serienmäßig die Fernbedienung mit Raumthermostatfunktion.

\_Estufa de pellet con diseño minimalista, gracias a la ausencia de bocas frontales; realizada en acero con la parte frontal de cerámica de colores (White, Black, Bordeaux) o efecto cuero (Skin) y de piedra (Sandstone, Soapstone). De serie el mando a distancia con función de termostato ambiente.

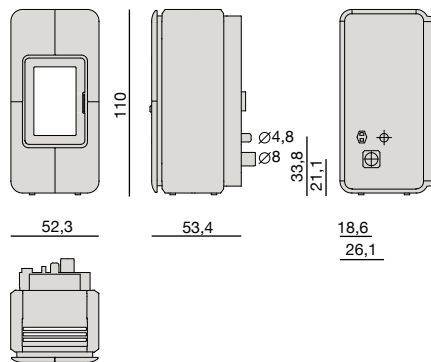

# Toba

/Air 8 /Comfort Air 8 /Hydro 22



# Nima

/Comfort Air 11.5

Technical Data > p. 166



\_Stufa a pellet realizzata in acciaio, con top e base in alluminio verniciato a polveri nero, fianchi in ceramica disponibili nei colori white, bordeaux, warm grey, sandstone, serpentino. Di serie il telecomando con funzione termostato ambiente.

\_Steel pellet stove, top and base in black powder coated aluminum, ceramic sides available in white, bordeaux, warm grey, sandstone, serpentino. Remote control with room thermostat as standard.

\_Poêle à pellet réalisé en acier, avec dessus et base en aluminium peint en noir avec des poudres, côtés en céramique disponibles dans les coloris white, bordeaux, warm grey, sandstone, serpentino. De série la télécommande avec fonction thermostat d'ambiance.

\_Pelletheizofen aus Stahl, mit Abdeckplatte und Unterteil aus schwarz pulverlackiertem Aluminium, die Keramikaußenseiten sind in den Farben white, bordeaux und warm grey, sandstone, serpentino. Serienmäßig die Fernbedienung mit Raumthermostatfunktion.

\_Estufa de pellets realizada en acero, con top y base de aluminio pintado con polvo negro, lados de cerámica disponibles en los colores white, bordeaux, warm grey, sandstone, serpentino. De serie el mando a distancia con función de termostato ambiente.

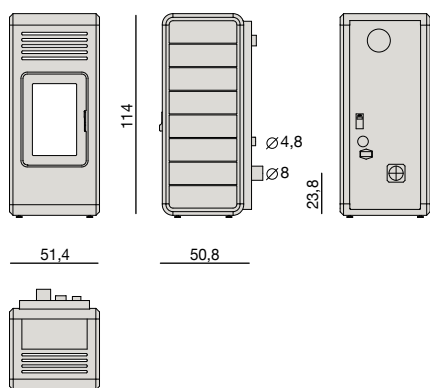



\_Stufa a pellet di dimensioni ridotte, realizzata in alluminio verniciato a polveri; disponibile nei colori: white, red, black, aluminium, bordeaux.

\_Small pellet stove, made of powder coated aluminum, available in the following colours: white, red, black, aluminium, bordeaux.

\_Poêle à pellet de dimensions réduites, réalisé en aluminium peint avec des poudres; disponible dans les coloris: white, red, black, aluminium, bordeaux.

\_Pelletheizofen mit reduzierten Abmessungen, aus pulverlackiertem Aluminium; in den Farben white, red, black, aluminium und bordeaux lieferbar.

\_Estufa de pellets de reducido tamaño, realizada en aluminio pintado con polvo; disponible en los colores: white, red, black, aluminium, bordeaux.

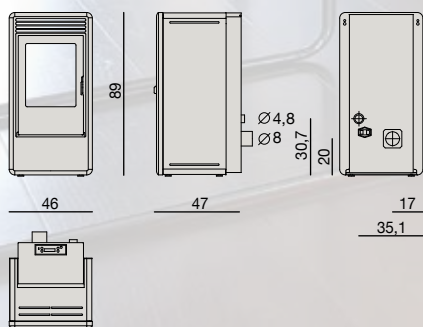

# Kaika

/Air 6 /Air Oyster 6

Technical Data > p. 162



\_Stufa a pellet dal look moderno realizzata in acciaio, con top in ghisa e fianchi in acciaio Bordeaux, Silver, Dark.

\_Pellet stove with a classic style, made of steel with cast-iron top and steel sides (Bordeaux, Silver, Dark).

\_Poêle à pellets forme moderne, réalisé en acier, avec dessus en fonte et côtés en acier de couleur Bordeaux, Silver ou Dark.

\_Moderner Pellet-Kaminofen aus Stahl, mit Abdeckplatte aus Gusseisen und Stahl-Seitenwänden, die in den Farben Bordeaux, Silver oder Dark erhältlich sind.

\_Estufa de pellet de aspecto moderno realizada en acero, con tapa de aleación y lados de acero Bordeaux, Silver, Dark

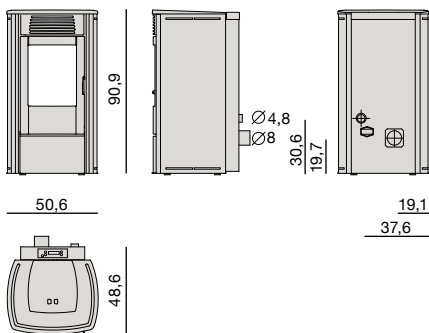

# Face

/Air 6

Technical Data > p. 162



\_Stufa a pellet dal look moderno realizzata in acciaio e ghisa. Top in ghisa e fianchi in acciaio verniciato (Bordeaux, White, Dark, Silver). Prodotto equipaggiato con candeletta in ceramica che garantisce dei tempi di accensione ridotti del 40%.

\_Pellet stove with a modern look, made of steel and cast iron. Cast iron top and coated steel sides (Burgundy, White, Dark, Silver). Product equipped with ceramic spark plug ensuring ignition times reduced by 40%.

\_Poêle à pellets au look moderne, réalisé en acier et en fonte. Couvercle en fonte et cotés latéraux en acier peint (Bordeaux, White, Dark, Silver). Produit équipé d'une bougie d'allumage en céramique qui garantit des temps d'allumage réduits de 40%.

\_Pelletofen mit modernem Look aus Stahl und Gusseisen. Top-Platte aus Gusseisen und Seitenwände aus lackiertem Stahl (Bordeaux, White, Dark, Silver). Mit einer Keramikzündkerze, die um 40% reduzierte Einschaltzeiten gewährleistet, ausgestattet Produkt.

\_Estufa de pellet de diseño moderno realizada con acero y hierro colado. Encimera de hierro colado y laterales de acero pintado (Bordeaux, White, Dark, Silver). Producto equipado con bujía de cerámica que garantiza tiempos de encendido reducidos un 40%.

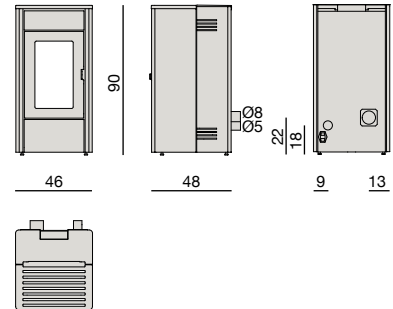

# Amy

/Air 6

Technical Data > p. 163



\_Stufa a pellet dal look moderno realizzata in acciaio e ghisa. Top in ghisa, fianchi in acciaio verniciato nei colori Bordeaux, White e Dark.

\_Pellet stove with a classic style, made of steel with cast-iron top and steel sides (Bordeaux, White, Dark).

\_Poêle à pellets forme moderne, réalisé en acier, avec dessus en fonte et côtés en acier de couleur Bordeaux, White ou Dark.

\_Moderner Pellet-Kaminofen aus Stahl, mit Abdeckplatte aus Gusseisen und Stahl-Seitenwänden, die in den Farben Bordeaux, White oder Dark erhältlich sind.

\_Estufa de pellet de aspecto moderno realizada en acero, con tapa de aleación y lados de acero Bordeaux, White, Dark.

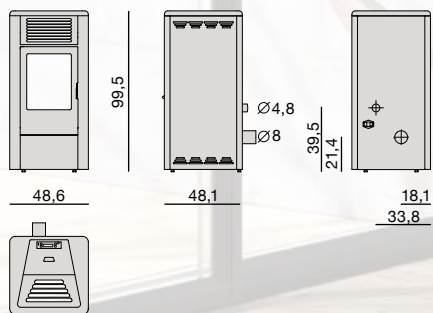

# Giò

/Air 8

Technical Data > p. 163





\_Stufa a pellet canalizzabile realizzata in acciaio e ghisa. Top in ghisa e fianchi laterali in acciaio verniciato Bordeaux, White, Dark. Preciso e semplificato controllo del flusso d'aria (anteriore-posteriore) tramite manopola che comanda un attuatore elettrico.

\_Ductable steel and cast iron pellet stove. Cast iron top and painted steel Bordeaux, White, Dark and Silver side panels. Accurate and simplified air flow control (front-rear) with a knob that controls an electronic actuator.

\_Poêle à pellets canalisable réalisé en acier et en fonte. Couvercle en fonte et flancs latéraux en acier peint Bordeaux, White. Contrôle précis et simplifié du flux d'air (antérieur-postérieur) au moyen d'une poignée qui commande un actionneur électrique.

\_Kanaliserbarer Pelletofen aus Stahl und Gusseisen. Abdeckplatte aus Gusseisen und Seitenwände aus lackiertem Stahl in Bordeaux, White, Dark. Präzise und vereinfachte Kontrolle des (vorderen-hinteren) Luftstroms mittels Regler, der einen elektrischen Stellantrieb auslöst.

\_Estufa de pellet canalizable realizada en acero y fundición. Parte superior de fundición y costados de acero pintado Bordeaux, White, Dark. Preciso y simplificado control del flujo de aire (delantero-trasero) mediante la manija giratoria que gestiona un actuador eléctrico.

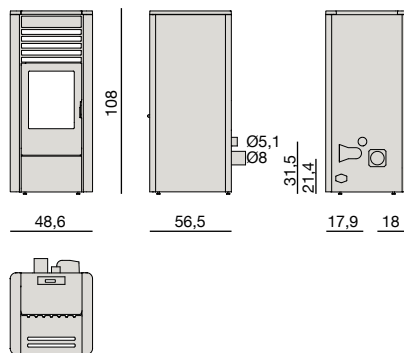

# Maggie

/ Canalizzabile 10  
Ductable 10  
Canalisable 10  
Kanalisiertbar 10  
Canalizable 10

Technical Data > p. 164





# Decò

/Air 8

Technical Data > p. 165



\_Stufa e pellet dal design classico con rivestimento e focolare interamente realizzati in ghisa color Black o ghisa smaltata in color verde. L'apertura del serbatoio pellet a scivolamento garantisce una estrema facilità delle operazioni di caricamento. Grazie ad un'altezza contenuta e la presenza di uno scarico fumi superiore, questo prodotto è ideale per ottimizzare lo spazio abitativo. Questa stufa è caratterizzata da una fiamma particolarmente bella da ammirare. Di serie il telecomando con funzione termostato ambiente.

\_Classic-style pellet stove, with cladding and firebox entirely made of cast iron in Black or enamelled cast iron in Green. The sliding opening of the pellet tank makes loading operations extremely easy. Thanks to its low height and the presence of a top smoke outlet, this product is the perfect solution for optimising the living space. This stove has a flame that is fascinating to look at. Remote control with room thermostat as standard.

\_Poêle à pellets au design classique avec revêtement et foyer entièrement réalisés en fonte couleur Black ou fonte émaillée de couleur verte. L'ouverture du réservoir à pellets à glissière facilite considérablement les opérations de chargement. Grâce à une hauteur réduite et à la présence d'une évacuation des fumées supérieure, ce produit est idéal pour optimiser l'espace d'habitation. Ce poêle est caractérisé par une flamme particulièrement belle à admirer. De série la télécommande avec fonction thermostat d'ambiance.

\_Ein Pelletofen mit klassischem Design, mit Verkleidung und Feuerraum ganz aus Gusseisen in der Farbe Black oder mit grünem Email-Gusseisen. Die Schiebeöffnung des Pelletbehälters gewährleistet äußerste Benutzerfreundlichkeit beim Beschicken. Dieses Produkt ist dank seiner geringen Höhe und dem oberen Rauchauslass ideal, um den Wohnraum zu optimieren. Der Ofen zeichnet sich durch eine besonders schön anzusehende Flamme aus. Serienmäßig die Fernbedienung mit Raumthermostatfunktion.

\_Estufa de pellet de diseño clásico con revestimiento y hogar completamente de hierro colado color Black o hierro colado esmaltado de color verde. La apertura del depósito de pellet con sistema deslizante facilita las operaciones de carga. Gracias a una altura limitada y a la presencia de una descarga de humos superior, este producto es ideal para optimizar el espacio de la vivienda. Esta estufa se caracteriza por una llama muy bella. De serie el mando a distancia con función de termostato ambiente.

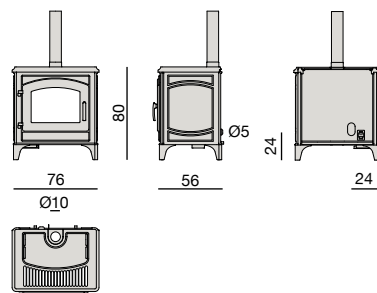



\_Stufa e pellet dal design classico-contemporaneo; ha un rivestimento in acciaio verniciato color Black e porta in ghisa. Gestione intelligente della combustione tramite Active+. Di serie il telecomando con funzione termostato ambiente.

\_Pellet-fuelled stove with a classic-contemporary design. It has a Black painted steel casing and a cast iron door. Intelligent combustion management with Active+. Remote control with room thermostat as standard.

\_Poêle à pellets au design classique et contemporain à la fois ; il possède un revêtement en acier laqué noir et une porte en fonte. Gestion intelligente de la combustion grâce à Active+. De série la télécommande avec fonction thermostat d'ambiance.

\_Ofen und Pelletofen von klassisch-modernem Design; Verkleidung aus lackiertem Stahl Farbe Black und Tür aus Gusseisen. Intelligente Regelung der Verbrennung über Active+. Serienmäßig die Fernbedienung mit Raumthermostatfunktion.

\_ Estufa de pellet de diseño clásico-contemporáneo; tiene un revestimiento en acero pintado de color negro y puerta de fundición. Gestión inteligente de la combustión mediante Active+. De serie el mando a distancia con función de termostato ambiente.

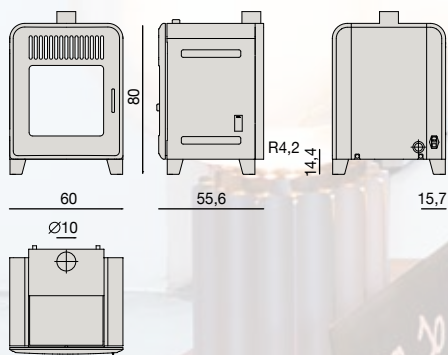

# Cute

/Air 8

Technical Data > p. 164





\_Stufa e pellet dal design minimale; ha un rivestimento in acciaio verniciato color Black e griglia frontale in ceramica Black, White o in Serpentino. Gestione intelligente della combustione tramite Active+. Di serie il telecomando con funzione termostato ambiente.

\_Pellet-fuelled stove with a minimal design. It is fitted with a Black painted steel coating and has a Black, White o Serpentine ceramic grid at the front. Intelligent combustion management with Active+. Remote control with room thermostat as standard.

\_Poêle à pellets au design minimaliste ; il possède un revêtement en acier laqué noir et une grille frontale en céramique noire, blanche ou en pierre serpentine. Gestion intelligente de la combustion grâce à Active+. Remote control with room thermostat as standard.

\_Ofen und Pelletofen von minimalistischem Design; Verkleidung aus lackiertem Stahl Farbe Black und frontales Gitter aus Keramik in Black, White oder Serpentino. Intelligente Regelung der Verbrennung über Active+. Serienmäßig die Fernbedienung mit Raumthermostatfunktion.

\_Estufa de pellet de diseño minimalista, tiene un revestimiento en acero pintado de color Negro y rejilla frontal de cerámica Negra, Blanca o en Serpentin. Gestión inteligente de la combustión mediante Active+. De serie el mando a distancia con función de termostato ambiente. De serie el mando a distancia con función de termostato ambiente.

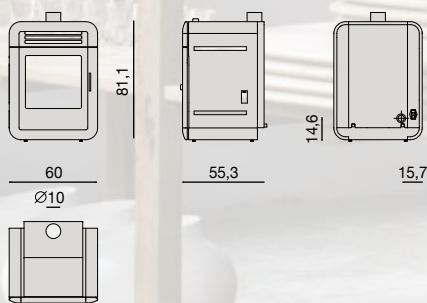

# Thema

/Air 8

Technical Data > p. 165





# Stream

/Comfort Air 12

Technical Data > p. 168



\_Stufa a pellet senza bocchette frontali realizzata con struttura in acciaio verniciato, porta in vetro e rivestimento frontale in serpentino o acciaio verniciato color White, Bordeaux, Dark. Gestione intelligente della combustione tramite Active+. Di serie il telecomando con funzione termostato ambiente. Dotata di due ventilatori regolabili in modo indipendente tramite telecomando.

\_Pellet stove with no front vents, made with a painted steel structure, glass door and serpentine stone or painted steel cladding, either White, Bordeaux, Dark. Intelligent combustion management with Active+. Remote control with room thermostat as standard. Fitted with two fans that can be set separately with a remote control.

\_Poêle à pellets sans bouche frontale, réalisé grâce à une structure en acier peint, porte en verre et revêtement frontal en pierre serpentine ou en acier peint de couleur blanche, bordeaux, sombre. Gestion intelligente de la combustion grâce à Active+. De série la télécommande avec fonction thermostat d'ambiance. Équipé de deux ventilateurs réglables de manière indépendante au moyen d'une télécommande.

\_Pelletofen ohne frontale Luftöffnungen mit Korpus aus lackiertem Stahl, Glastür und Frontverkleidung aus Serpentin oder lackiertem Stahl in den Farben White, Bordeaux, Dark. Intelligente Regelung der Verbrennung über Active+. Serienmäßig die Fernbedienung mit Raumthermostatfunktion. Mit zwei Ventilatoren, die mit einer Fernbedienung unabhängig voneinander eingestellt werden können.

\_Estufa de pellet sin bocas frontales, realizada con estructura de acero pintado, puerta de cristal y revestimiento frontal en serpentín o acero pintado color White, Bordeaux, Dark. De la combustión mediante Active+. De serie el mando a distancia con función de termostato ambiente. Tiene dos ventiladores regulables de forma independiente con el mando a distancia.

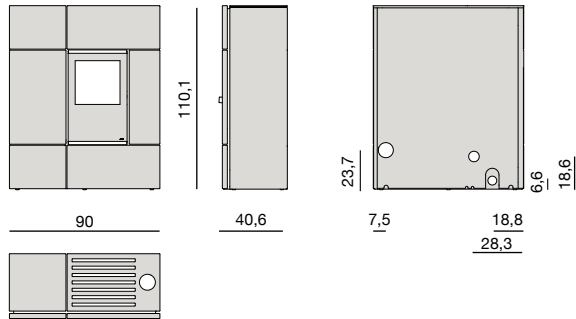



# Philo

/Comfort Air 9

Technical Data > p. 168









Flussi d'aria orientabili a piacimento.  
Air flows adjustable as needed.  
Flux d'air orientables librement.  
Nach Wunsch regelbare Luftströme.  
Flujos de aire orientables al gusto.

\_Stufa a pellet particolarmente adatta per spazi ristretti, grazie alla profondità molto ridotta (27cm); caratterizzata da due flussi d'aria orientabili a piacimento, in base alle necessità di riscaldamento dell'ambiente; top in alluminio, fianchi in acciaio verniciato nero e frontale in metallo color White, Bordeaux, Black, Bronze (o Aluminium). Di serie il telecomando con funzione termostato ambiente.

\_A very shallow pellet stove (only 27 cm), particularly suitable for small spaces. Two air flows adjustable as needed according to the heating requirements of the room. Aluminium top, black painted steel sides and metal front (White, Bordeaux, Black, Bronze or Aluminium). Remote control with room thermostat as standard.

\_Poêle à pellets spécialement indiqué pour les espaces restreints, grâce à une profondeur très réduite (27 cm) ; caractérisé par deux flux d'air orientables librement, selon les besoins de chauffage de la pièce ; dessus en aluminium, côtés en acier peint en noir et façade en métal de couleur White, Bordeaux, Black, Bronze (ou Aluminium). De série la télécommande avec fonction thermostat d'ambiance.

\_Dank seiner geringen Tiefe (27 cm), eignet sich dieser Pellet-Kaminofen besonders gut für enge Räume. Er zeichnet sich durch zwei, nach Wunsch und je nach Wärmebedarf, regelbare Luftströme aus. Abdeckplatte aus Aluminium, schwarz lackierte Stahl-Seitenwände und metallene Frontseite, die in den Farben White, Bordeaux, Black, Bronze (oder Aluminium) erhältlich ist. Serienmäßig die Fernbedienung mit Raumthermostatfunktion.

\_Estufa de pellet especialmente adecuada para espacios pequeños, gracias a su reducida profundidad (27 cm), caracterizada por dos flujos de aire orientables al propio gusto, según a las necesidades de calefacción del ambiente, tapa de aluminio, lados de acero pintado en negro y frontal metálico de color White, Bordeaux, Black, Bronze (o Aluminium). De serie el mando a distancia con función de termostato ambiente.

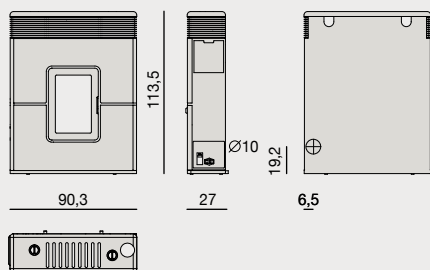

\_Stufa a pellet particolarmente adatta per spazi ristretti, flussi d'aria canalizzabili, frontale in acciaio verniciato nero, fianco e top in Serpentino. Di serie il telecomando con funzione termostato ambiente.

\_A pellet stove which is particularly suitable for confined spaces, ductable air flows, black painted steel front, Serpentino side and top. Remote control with room thermostat as standard.

\_Poêle à pellets particulièrement adapté aux espaces restreints, flux d'air pouvant être canalisés, façade en acier peint en noir, côtés et dessus en Serpentino. De série la télécommande avec fonction thermostat d'ambiance.

\_Pelletofen, der sich besonders bei Platzproblemen eignet, kanalisierbarer Luftfluss, Vorderteil aus schwarz lackiertem Stahl, Seitenteil und Top aus Serpentino. Serienmäßig die Fernbedienung mit Raumthermostatfunktion.

\_Estufa de pellet especialmente adaptada para espacios restringidos, flujos de aire canalizables, frontal de acero pintado negro, lado y tapa de Serpentino. De serie el mando a distancia con función de termostato ambiente.

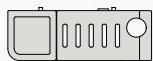
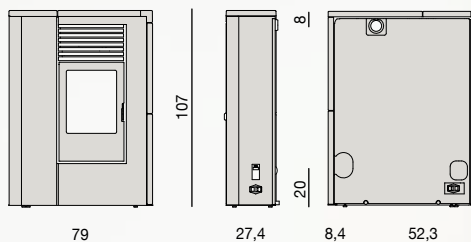

# Flair

/Comfort Air 8

Technical Data > p. 167



\_Stufa a pellet particolarmente adatta per spazi ristretti, flussi d'aria canalizzabili, frontale in acciaio verniciato nero, fianco e top in ceramica color bianco, nero e bordeaux. Di serie il telecomando con funzione termostato ambiente.

\_A pellet stove which is particularly suitable for confined spaces, ductable air flows, black painted steel front, white, black and bordeaux ceramic side and top. Remote control with room thermostat as standard.

\_Poêle à pellets particulièrement adapté pour les espaces restreints, flux d'air pouvant être canalisés, façade en acier peint en noir, côtés et dessus en céramique blanche, noire et bordeaux. De série la télécommande avec fonction thermostat d'ambiance.

\_Pelletofen, der sich besonders bei Platzproblemen eignet, kanalisierbarer Luftfluss, Vorderteil aus schwarz lackiertem Stahl, Seitenteil und Top aus Keramik in den Farben weiß, schwarz und Bordeaux. Serienmäßig die Fernbedienung mit Raumthermostatfunktion.

\_Estufa de pellet especialmente adaptada para espacios restringidos, flujos de aire canalizables, frontal de acero pintado negro, lado y tapa de cerámica de color blanco, negro o burdeos. De serie el mando a distancia con función de termostato ambiente.

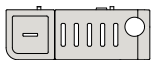
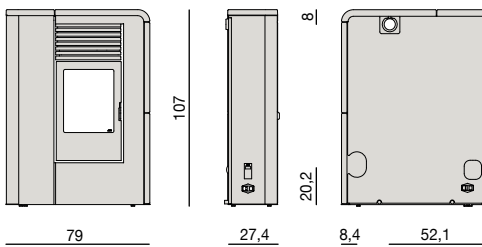

# Flat

/Comfort Air 8

Technical Data > p. 167



# Swing

/Hydro 23

Technical Data > p. 170









\_Stufa a pellet idro realizzata con struttura in acciaio, porta in vetro nero, top e fianchi in ceramica. Braciere in ghisa con sistema brevettato di avvio sicuro. Gestione intelligente della combustione tramite Active+. Pannello di controllo facile e intuitivo. Dotata di ventilatore ambiente.

\_Hydro pellet stove with steel structure, black glass door, ceramic top and sides. Cast iron brazier with safe start patented system. Intelligent combustion management with Active+. Easy and intuitive control panel. Fitted with a room fan.

\_Poêle à pellet hydro réalisé avec une structure en acier, une porte en verre noir, un couvercle et des flancs en céramique. Brasero en fonte avec système breveté de mise en marche sûre. Gestion intelligente de la combustion grâce à Active+. Panneau de contrôle facile et intuitif. Il est doté d'un ventilateur ambiant.

\_Wasserführender Pelletofen mit Stahlkorpus, Tür aus schwarzem Glas, Top und Außenseiten aus Keramik. Brennschale aus Gusseisen, mit sicherem patentierten Zündsystem. Intelligente Regelung der Verbrennung über Active+. Einfache und intuitive Bedienblende. Mit Raumventilator.

\_Estufa de pellet idro realizada con estructura de acero, puerta de cristal negro, parte superior y laterales de cerámica. Brasero de fundición con sistema patentado de arranque seguro. Gestión inteligente de la combustión mediante Active+. Panel de control fácil e intuitivo. Con ventilador ambiente.

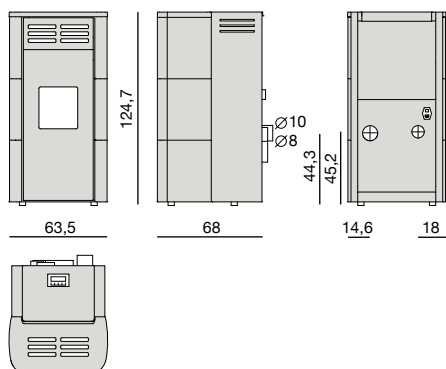

# Flux

/Hydro 16

Technical Data > p. 169



\_Stufa a pellet dal design minimale particolarmente adatta per spazi ristretti; ha rivestimento in acciaio verniciato color Black, Bordeaux, White e focolare nero. Gestione intelligente della combustione tramite Active+.

\_Pellet-fuelled stove with a minimal design, particularly suited for confined spaces. It is fitted with a Black, Bordeaux, White painted casing and a black firebox. Intelligent combustion management with Active+.

\_Poêle à pellets au design minimaliste idéal pour les espaces réduits ; il possède un revêtement en acier coloris noir, bordeaux, blanc et un foyer noir. Gestion intelligente de la combustion grâce à Active+.

\_Pelletofen von minimalistischem Design, besonders geeignet für kleine Räume; Verkleidung aus lackiertem Stahl Farbe Black, Bordeaux, White und Feuerraum schwarz. Intelligente Regelung der Verbrennung über Active+.

\_Estufa de pellet de diseño minimalista especialmente adecuada para espacios reducidos; tiene un revestimiento de acero pintado de color Negro, Burdeos o Blanco y hogar negro. Gestión inteligente de la combustión mediante Active+.

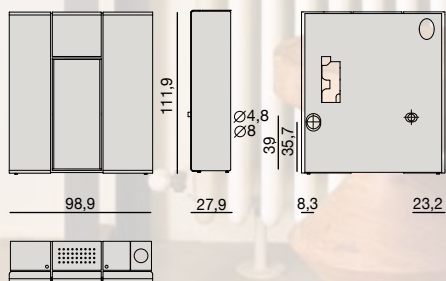

\_Stufa a pellet dal look moderno realizzata in acciaio, con top in ghisa e fianchi in acciaio color Bordeaux, Silver, White, Dark, Inox no-touch.

\_Pellet stove with a modern style, made of steel with cast-iron top and steel sides (Bordeaux, Silver, White, Dark, Inox no-touch).

\_Poêle à pellets forme moderne, réalisé en acier, avec dessus en fonte et côtés en acier de couleur Bordeaux, Silver, White, Dark ou Inox no-touch.

\_Moderner Pellet-Kaminofen aus Stahl, mit Abdeckplatte aus Gusseisen und Stahl-Seitenwänden, die in den Farben Bordeaux, Silver, White, Dark oder Inox no-touch erhältlich sind.

\_Estufa de pellet de aspecto moderno realizada en acero, con tapa de aleación y lados de acero color Bordeaux, Silver, White, Dark, Inox no-touch.

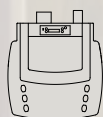
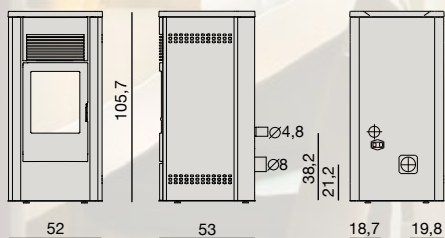

# Ego Hydro

/Hydro 12

Technical Data > p. 170



\_Stufa a pellet dal look classico realizzata in acciaio, con top in ghisa e fianchi in ceramica color Bordeaux, Old Amber, Salt and Pepper, Soapstone, Serpentino.

\_Pellet stove with a modern style, made of steel with cast-iron top and ceramic sides (Bordeaux, Old Amber, Salt & Pepper, Soapstone, Serpentino).

\_Poêle à pellets forme classique, réalisé en acier, avec dessus en fonte et côtés en céramique de couleur Bordeaux, Old Amber, Salt and Pepper ou Soapstone, Serpentino.

\_Klassischer Pellet-Kaminofen aus Stahl, mit Abdeckplatte aus Gusseisen und Keramik-Seitenwänden, die in den Farben Bordeaux, Old Amber, Salt and Pepper oder Speckstein, Serpentino erhältlich sind.

\_Estufa de pellet de aspecto clásico realizada en acero, con tapa de aleación y lados de cerámica color Bordeaux, Old Amber, Salt and Pepper, Soapstone, Serpentino.

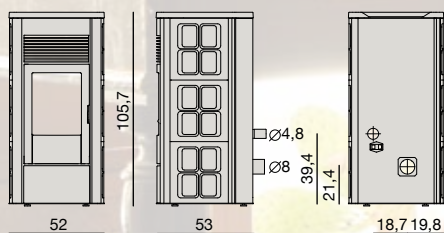

# Star Hydro

## /Hydro 12

Technical Data > p. 171





# Musa Hydro

/Hydro 15 /Hydro 22

Technical Data > p. 171



\_Stufa a pellet dal look moderno realizzata in acciaio, con top in ghisa e fianchi in acciaio color Bordeaux, Silver, White, Dark.

\_Pellet stove with a modern style, made of steel with cast-iron top and steel sides (Bordeaux, Silver, White, Dark).

\_Poêle à pellets forme moderne, réalisé en acier, avec dessus en fonte et côtés en acier de couleur Bordeaux, Silver, White ou Dark.

\_Moderner Pellet-Kaminofen aus Stahl, mit Abdeckplatte aus Gusseisen und Stahl-Seitenwänden, die in den Farben Bordeaux, Silver, White oder Dark erhältlich sind.

\_Moderner Pellet-Kaminofen aus Stahl, mit Abdeckplatte aus Gusseisen und Stahl-Seitenwänden, die in den Farben Bordeaux, Silver, White oder Dark erhältlich sind.

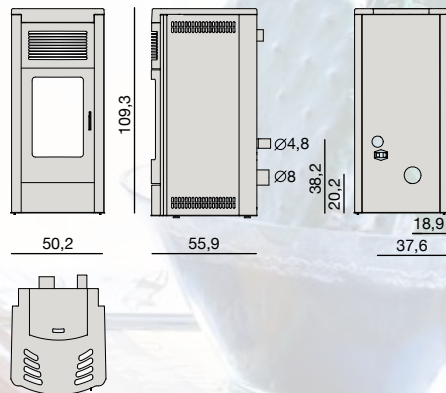

\_Stufa a pellet dal look classico realizzata in acciaio, con top e fianchi in ceramica color Bordeaux, Old Amber, Salt and Pepper.

\_Pellet stove with a classic style, made of steel with ceramic top and sides (Bordeaux, Old Amber, Salt & Pepper).

\_Poêle à pellets forme classique, réalisé en acier, avec dessus et côtés en céramique de couleur Bordeaux, Old Amber ou Salt and Pepper.

\_Klassischer Pellet-Kaminofen aus Stahl, mit Abdeckplatte und Seitenwänden aus Keramik, die in den Farben Bordeaux, Old Amber, Salt and Pepper erhältlich sind.

\_ Estufa de pellet de aspecto clásico realizada en acero, con tapa y lados de cerámica color Bordeaux, Old Amber, Salt and Pepper.

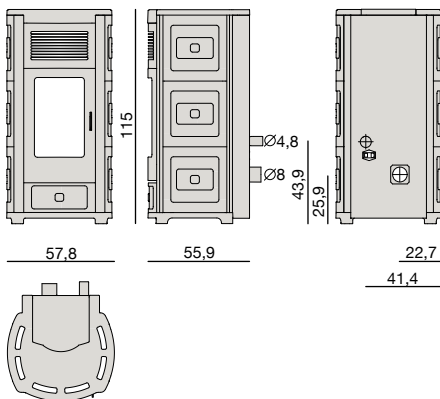

# Suite Hydro

/Hydro 15 /Hydro 22

Technical Data > p. 172



\_Stufa a pellet dal look moderno realizzata in acciaio, con top e fianchi in ceramica color Bordeaux, Sand, White, Black, Serpentino.

\_Pellet stove with a modern style, made of steel with ceramic top and sides (Bordeaux, Sand, White, Black, Serpentino).

\_Poêle à pellets forme moderne, réalisé en acier, avec dessus et côtés en céramique de couleur Bordeaux, Sand, White, Black, Serpentino.

\_Moderner Pellet-Kaminofen aus Stahl, mit Abdeckplatte und Seitenwänden aus Keramik, die in den Farben Bordeaux, Sand, White, Black, Serpentino erhältlich sind.

\_Estufa de pellet de aspecto moderno realizada en acero, con tapa y lados de cerámica color Bordeaux, Sand, White, Black, Serpentino.

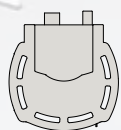
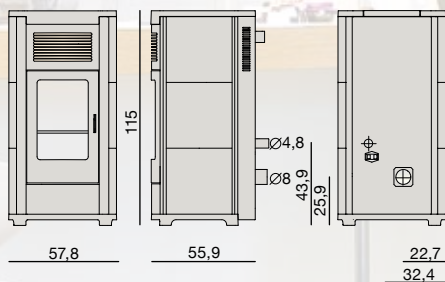

# Club Hydro

/Hydro 15 /Hydro 22

Technical Data > p. 172



# Duo

/Hydro Air 22

Technical Data > p. 169



\_Stufa a pellet dal look moderno realizzata in acciaio, con top e fianchi in ceramica color Bordeaux, White, Black. Gestione intelligente della combustione tramite Active+.

\_Pellet stove with a modern style, made of steel with ceramic top and sides (Bordeaux, White, Black). Intelligent combustion management with Active+.

\_Poêle à pellets forme moderne, réalisé en acier, avec dessus et côtés en céramique de couleur Bordeaux, White, Black. Gestion intelligente de la combustion grâce à Active+.

\_Moderner Pellet-Kaminofen aus Stahl, mit Abdeckplatte und Seitenwänden aus Keramik, die in den Farben Bordeaux, White, Black, erhältlich sind. Intelligente Regelung der Verbrennung über Active+.

\_Estufa de pellet de aspecto moderno realizada en acero, con tapa y lados de cerámica color Bordeaux, White, Black. Gestión inteligente de la combustión mediante Active+.

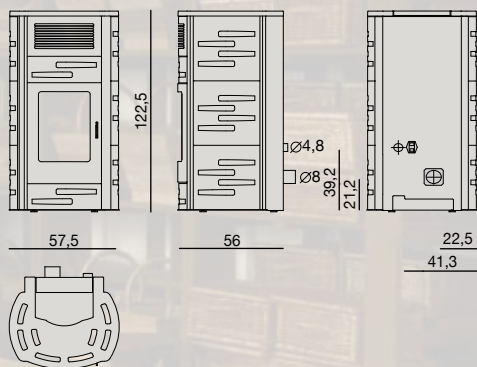

\_Le stufe con tecnologia HYDRO AIR consentono di riscaldare sia l'ambiente in cui è installata la stufa, tramite ventilazione forzata, sia l'acqua dei termosifoni. A differenza dei prodotti ad acqua tradizionali, la gestione della potenza all'aria è completamente controllabile dall'utente.

\_The stoves with HYDRO AIR technology allow to heat both the room in which the stove is installed, via forced ventilation, as well as the water in the radiators. Unlike traditional water products, the management of the air power can be fully controlled by the user.

\_Les poêles qui exploitent la technologie HYDRO-AIR permettent de chauffer aussi bien l'espace où le poêle est installé, grâce à la ventilation forcée, que l'eau des radiateurs. À la différence des produits à eau traditionnels, l'utilisateur peut contrôler complètement la puissance de l'air.

\_Die Kaminöfen mit HYDRO AIR Technologie ermöglichen sowohl das Heizen des Raums, in dem der Kaminofen aufgestellt ist, durch Zwangsbelüftung als auch das Erhitzen des Wassers der Heizkörper. Im Gegensatz zu den herkömmlichen wasserführenden Produkten kann die Raumleistung vollständig vom Benutzer gesteuert werden.

\_Las estufas con tecnología HYDRO AIR permiten calentar tanto el ambiente donde está instalada la estufa, mediante ventilación forzada, como el agua de los termosifones. A diferencia de los productos de agua tradicionales, la gestión de la potencia del aire puede ser controlada completamente por el usuario.





# Vivo 85 Hydro

/Hydro 22

Technical Data > p. 148

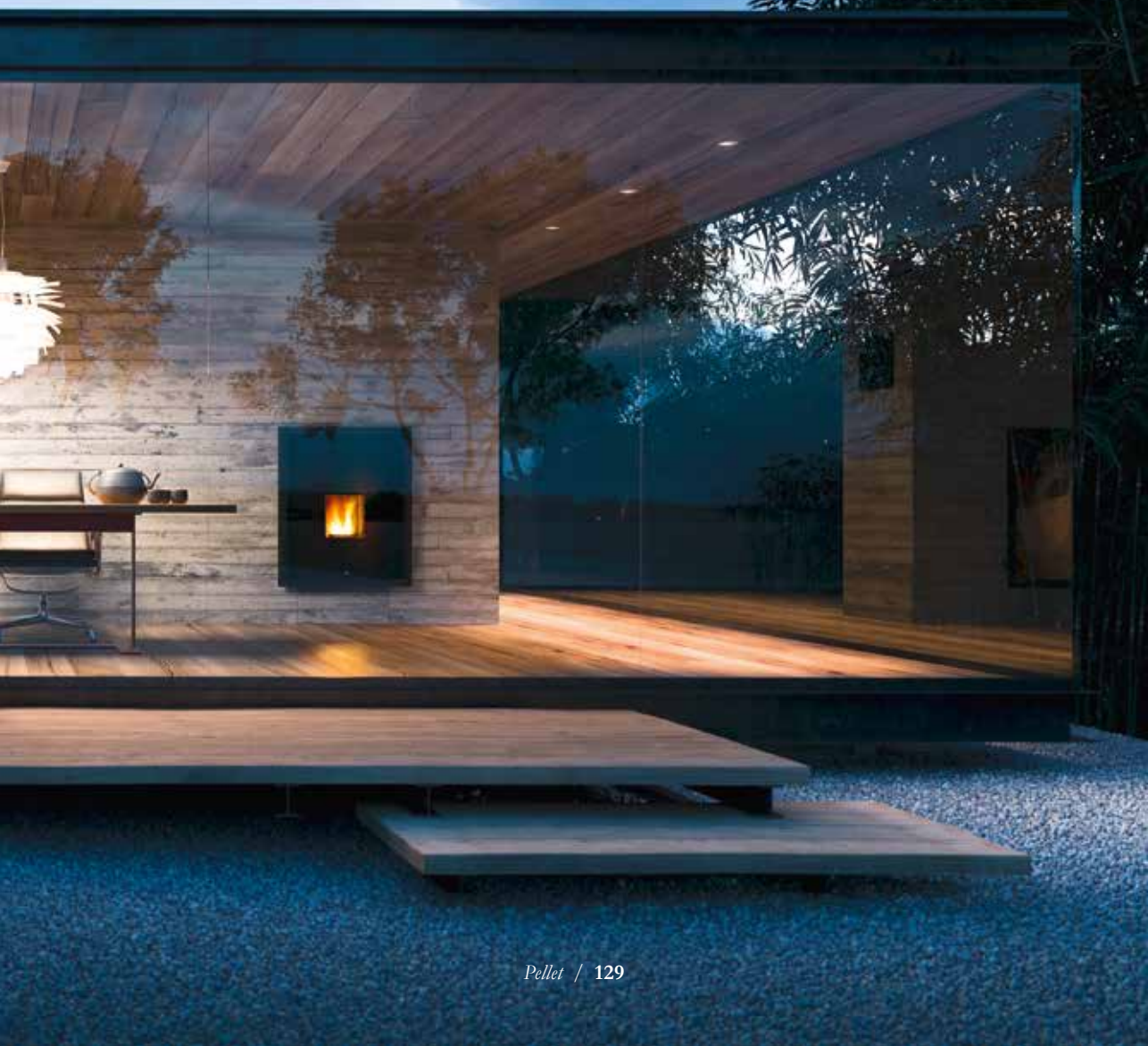



\_Camino a pellet hydro con porta esterna in vetro, senza bocchette frontali a vista (uscita aria perimetrale inferiore). La pulizia turbolatori può essere effettuata direttamente aprendo la porta mentre la manutenzione straordinaria risulta molto agevole grazie al sistema di estrazione su binari della struttura.

\_Hydro pellet fireplace with external glass door without exposed front vents (lower perimeter air outlet). The turbulators can be cleaned directly by opening the door, while extraordinary maintenance is very easy to perform thanks to the structure's rail extraction system.

\_Cheminée à pellets hydro avec porte extérieure en verre, sans bouche frontale apparente (sortie d'air périmétrale inférieure). Le nettoyage des turbulateurs peut être effectué directement en ouvrant la porte et l'entretien extraordinaire est extrêmement facilité grâce au système d'extraction sur rails de la structure.

\_Pelletkamin mit äußerer Glastür, ohne sichtbare frontale Luftöffnungen (umlaufender Luftauslass unten). Die Turbulatoren können direkt bei Öffnen der Tür gereinigt werden, während die außerordentliche Wartung sich dank des Auszugssystems auf am Korpus befindlichen Schienen ausgesprochen einfach gestaltet.

\_Chimenea de pellet hydro con puerta externa de cristal, sin bocas frontales a vista (salida de aire perimetral inferior). La limpieza de los tubulares se puede realizar directamente abriendo la puerta, mientras el mantenimiento extraordinario es muy fácil gracias al sistema de extracción sobre guías de la estructura.

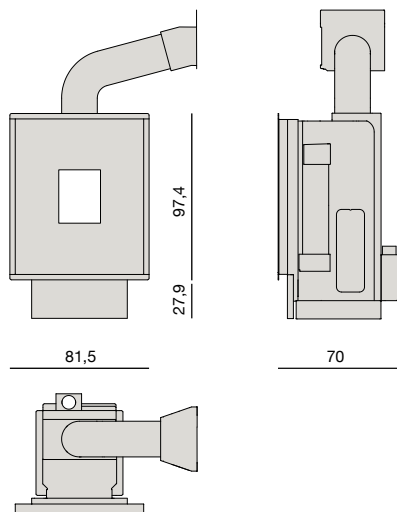

\_Camino a pellet dal formato panoramico, con fiamma più larga e piacevole. Abbinabile ai sistemi di canalizzazione dell'aria Comfort Air Basic o Comfort Air Slim per riscaldare più ambienti anche non comunicanti. Il braciere e il focolare sono in ghisa nera. La gestione della combustione avviene automaticamente tramite Active+. Questo camino può essere installato in prossimità del pavimento. Di serie il telecomando con funzione termostato ambiente.

\_Pellet fireplace with a large view, a larger and even more attractive flame. Can be combined with Comfort Air Basic or Comfort Air Slim to heat several rooms, even non-communicating ones. Black cast iron brazier and firebox. Combustion is managed automatically with Active+. This fireplace can be installed close to the floor. Remote control with room thermostat as standard.

\_Cheminée à pellet au format panoramique, avec une flamme plus large et agréable. Elle peut être combinée aux systèmes de canalisation de l'air Comfort Air Basic ou Comfort Air Slim pour chauffer plusieurs espaces même s'ils ne communiquent pas. Le brasero et le foyer sont en fonte noire. La gestion de la combustion advient automatiquement grâce à Active+. Cette cheminée peut être installée à proximité du sol. De série la télécommande avec fonction thermostat d'ambiance.

\_Pelletkamin im Panoramaformat, mit breiterer und angenehmer Flamme. Mit den Systemen zur Luftkanalisation Comfort Air Basic oder Comfort Air Slim kombinierbar, um mehrere, selbst nicht verbundene Räume zu heizen. Brennschale und Brennkammer bestehen aus schwarzem Gusseisen. Die Regelung der Verbrennung erfolgt automatisch über Active+. Dieser Kaminofen kann in Bodennähe installiert werden. Serienmäßig die Fernbedienung mit Raumthermostatfunktion.

\_Chimenea de pellet con formato panorámico y llama más amplia y agradable. Se puede combinar con los sistemas de canalización del aire Comfort Air Basic o Comfort Air Slim para la calefacción de varios ambientes, incluso si no se comunican entre sí. El brasero y el hogar son de fundición negra. La combustión se controla automáticamente mediante Active+. Esta chimenea se puede instalar cerca del suelo. De serie el mando a distancia con función de termostato ambiente.

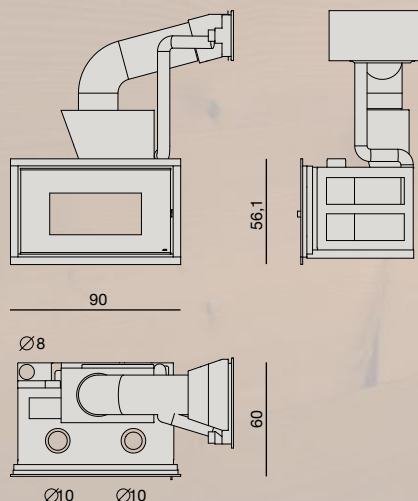

# Vivo 90

/Comfort Air

Technical Data > p. 142



\_Rivestimento frontale costituito da una cornice in pietra Ardesia a spacco naturale. Abbinabile a Vivo 80/90 Comfort Air e Vivo 80 Hydro.

\_Front cladding consists of a natural split slate frame. Can be combined with Vivo 80/90 Comfort Air and Vivo 80 Hydro.

\_Habillage frontal constitué d'un encadrement en pierre d'ardoise fendue naturelle. Combinable avec Vivo 80/90 Comfort Air et Vivo 80 Hydro.

\_Frontverkleidung, die aus einer Einfassung aus unbehandeltem Schiefernaturstein besteht. Kombinierbar mit Vivo 80/90 Comfort Air und Vivo 80 Hydro.

\_Revestimiento frontal formado por un marco de piedra Ardesia con corte natural. Se puede instalar junto a Vivo 80/90 Comfort Air y Vivo 80 Hydro.

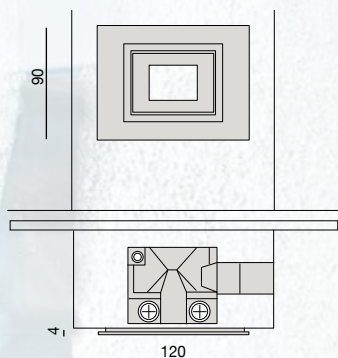

# Prime

/Vivo 80-90 Comfort Air /Vivo 80 Hydro

Technical Data > p. 142/144/146





\_Rivestimento frontale costituito da una cornice in pietra grigio-sabbiata. Abbinabile a Vivo 80/90 Comfort Air e Vivo 80 Hydro.

\_The front cladding consists of a gray-stone sandblasted frame. Can be combined with Vivo 80/90 Comfort Air and Vivo 80 Hydro.

\_Habillage frontal constitué d'un encadrement en pierre grise-sablée. Combinable avec Vivo 80/90 Comfort Air et Vivo 80 Hydro.

\_Frontverkleidung, die aus einer Einfassung aus grau-sandgestrahltem Naturstein besteht. Kombinierbar mit Vivo 80/90 Comfort Air und Vivo 80 Hydro.

\_Revestimiento frontal formado por un marco de piedra gris-arenada. Se puede instalar junto a Vivo 80/90 Comfort Air y Vivo 80 Hydro.

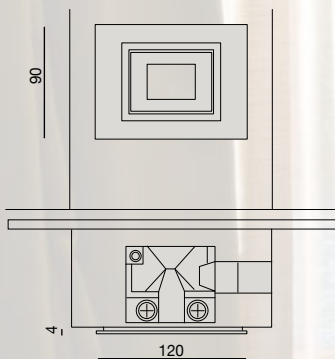

# Modus

/Vivo 80-90 Comfort Air /Vivo 80 Hydro

Technical Data > p. 142/144/146



\_Rivestimento frontale costituito da una cornice in acciaio verniciato a polveri con finitura bronzo. Abbinabile a Vivo 80/90 Comfort Air e Vivo 80 Hydro.

\_Front cladding consists of a steel frame with bronze powder coat finish. Can be combined with Vivo 80/90 Comfort Air and Vivo 80 Hydro.

\_Habillage frontal constitué d'un encadrement en acier peint avec des poudres et finition bronze. Combinable avec Vivo 80/90 Comfort Air et Vivo 80 Hydro.

\_Frontverkleidung, die aus einer Einfassung aus pulverlackiertem Stahl in Bronzefarben lackiert. Kombinierbar mit Vivo 80/90 Comfort Air und Vivo 80 Hydro.

\_Revestimiento frontal formado por un marco de acero pintado con polvo en acabado bronce. Se puede instalar junto a Vivo 80/90 Comfort Air y Vivo 80 Hydro.

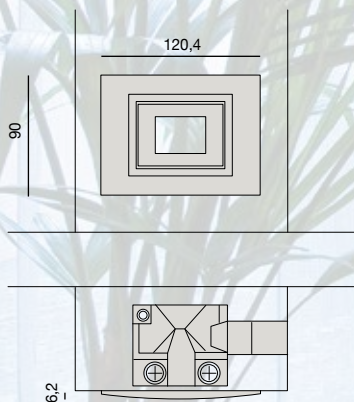

# Frame

/Vivo 80-90 Comfort Air /Vivo 80 Hydro

Technical Data > p. 142/144/146



\_Inserto a pellet con carica frontale tramite cassetto integrato, adatto per l'inserimento in focolari esistenti o per nuove installazioni. Disponibile in due misure (70 e 60).

\_Pellet insert with front loading via built-in drawer, suitable for being put inside existing fireplaces or for new installations. Available in two sizes (70 and 60).

\_Insert à pellets avec chargement en façade par tiroir intégré, adapté à une insertion dans des foyers existants ou pour de nouvelles installations. Disponible en deux formats (70 et 60).

\_Pelleteinsatz mit Frontladung durch eingebautes Schubfach, das sich für den Einbau in schon bestehende Feuerstellen oder Neuinstallationen eignet. Verfügbar in zwei Abmessungen (70 und 60).

\_Aplicación de pellet con carga frontal mediante cajón integrado, adaptado para la inserción en hogares existentes o para nuevas instalaciones. Disponible en dos medidas (70 y 60).

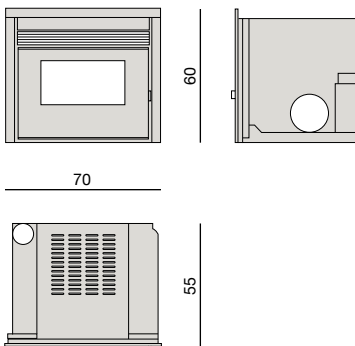

# Boxtherm

/Boxtherm

Technical Data > p. 150



# Vivo 90 Comfort Air

LA BELLEZZA DEL FORMATO PANORAMICO E LA PRATICITÀ DEL PELLETT

THE BEAUTY OF A LARGE VIEW AND THE CONVENIENCE OF PELLETS

LA BEAUTÉ DU FORMAT PANORAMIQUE ET LA PRATICITÉ DU PELLETT

DIE SCHÖNHEIT DES PANORAMAFORMATS UND DIE ANNEHMLICHKEITEN DER PELLETS

LA BELLEZA DEL FORMATO PANORÁMICO Y LA FUNCIONALIDAD DEL PELLETT

## FORMATO PANORAMICO E FOCOLARE NERO

in linea con le architetture più contemporanee.

## LARGE VIEW AND BLACK FIREBOX,

in line with the latest contemporary architectural solutions

## FORMAT PANORAMIQUE ET FOYER NOIR

qui s'assortissent avec les architectures les plus contemporaines

## PANORAMAFORMAT UND SCHWARZE BRENNKAMMER;

im Einklang mit der zeitgenössischen Architektur.

## FORMATO PANORÁMICO Y HOGAR NEGRO,

en línea con las arquitecturas más contemporáneas

## FIAMMA PIÙ LARGA E PIACEVOLE.

## LARGE AND PLEASANT FLAME.

## UNE FLAMME LARGE ET AGRÉABLE.

## BREITE UND ANGENEHME FLAMME.

## LLAMA MÁS AMPLIA Y AGRADABLE.

## POSSIBILITÀ DI POSIZIONAMENTO IN PROSSIMITÀ' DEL PAVIMENTO.

## OPTION OF INSTALLING IT CLOSE TO THE FLOOR.

## POSSIBILITÉ DE POSITIONNEMENT À PROXIMITÉ DU SOL

## AUFSTELLMÖGLICHKEIT IN BODENNÄHE.

## POSIBILIDAD DE COLOCACIÓN CERCA DEL SUELO.

## NUOVE INTERFACCIE UTENTE

Grazie ad Active+, è possibile comandare e dialogare con la stufa anche tramite smartphone e tablet.

## NEW USER INTERFACES

Thanks to Active+ you can control and interact with the fireplace, even with a smartphone or tablet.

## NOUVELLES INTERFACES UTILISATEUR

Grâce à Active+, il est possible de commander et de dialoguer avec la cheminée à partir d'un smartphone et d'une tablette aussi.

## NEUE BENUTZER-SCHNITTSTELLEN.

Dank Active+ kann der Kaminofen auch über Smartphone und Tablet bedient werden.

## NUEVAS INTERFACES DE USUARIO

Gracias a Active+, es posible controlar y comunicarse con la chimenea incluso mediante smartphone y tableta.

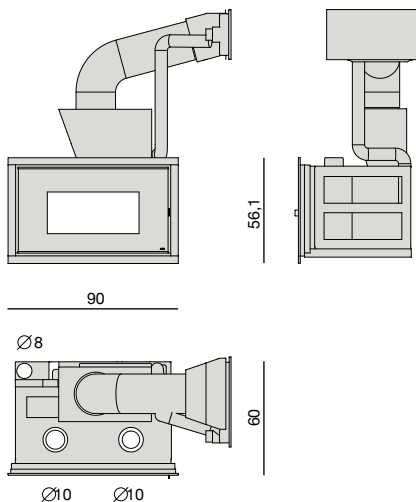

### COMFORT AIR \*\*\*

POWER max	10,5 - 9.030 [kW-kcal/h]
POWER min	3,5 - 3.010 [kW-kcal/h]
	93,1 / 94,4 [%]
	58 (con tubo) [l]
	pellet Ø 6-8 x 3÷40 [mm]
	~ 0,8/ ~ 2,2 [kg/h]
	48/ 17 [h]
	226/40 - 258/35 - 301/30 [m³]
	8 [cm]
	180 [kg]
	160 [°C]
	9 [g/s]

CE

EN 14785

UZ-37

BlmSchV Stufe 2

ART. 15a B-VG 2015

REGENSBURGER/  
AACHENER/  
MÜNCHENER BStV



Conto Termico





# Vivo 80 Comfort Air

Grazie ai due ventilatori indipendenti regolabili elettronicamente con il telecomando di serie, Comfort Air® consente un preciso controllo della diffusione del calore tra i vari ambienti dove l'aria viene canalizzata. Disponibile con bocchette tradizionali (Comfort Air Basic) o con motore remoto e bocchette dal design minimale (Comfort Air Slim).

Thanks to two independent fans electrically adjustable with the remote control as standard, Comfort Air® allows precise control of the diffusion of heat between the different environments where the air is channeled. Available with traditional hot air outlets (Comfort Air Basic) or with remote motor and minimal design hot air outlets (Comfort Air Slim).

Grâce aux deux ventilateurs indépendants, réglables électriquement par la télécommande de série, Comfort Air® permet un contrôle précis de la diffusion de la chaleur dans les différents pièces où l'air est canalisé. Disponible avec des bouches d'air classiques (Comfort Air Basic) ou avec un moteur à distance et des bouches d'air au design épuré (Comfort Air Slim).

Durch die zwei mit serienmäßiger Fernbedienung unabhängig voneinander elektronisch einstellbaren Ventilatoren, ermöglicht Comfort Air® eine genaue Kontrolle der Wärmeverteilung in den einzelnen Räumen, denen die Luft zugeführt wird. Verfügbar mit traditionellen Düsen (Comfort Air Basic) oder mit Remote- Motor und Düsen im minimalistischen Design (Comfort Air Slim).

Gracias a los dos ventiladores independientes con regulación electrónica mediante el mando a distancia de serie, Comfort Air® permite un preciso control de la difusión del calor entre las distintas habitaciones por las que se canaliza el aire. Disponible con salidas tradicionales (Comfort Air Basic) o con motor remoto y salidas de diseño minimalista (Comfort Air Slim).

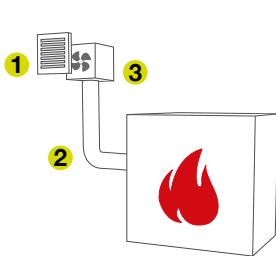

## COMFORT AIR BASIC

- 1 Diffusori multi 20  
Diffusers multi 20  
Diffuseurs multi 20  
Luftverteiler multi 20  
Difusores multi 20
- 2 Canalizzazione ø100 mm  
Ducting ø100 mm  
Canalisation ø100 mm  
Kanalisierung ø100 mm  
Canalización ø100 mm
- 3 Motore posizionato dietro il diffusore  
Motor positioned behind the diffuser  
Moteur positionné derrière le diffuseur  
Motor hinter dem luftverteiler  
Motor posicionado detrás del difusor

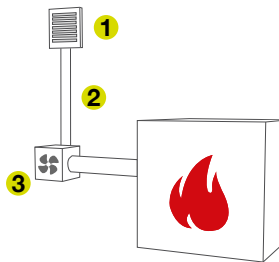

## COMFORT AIR SLIM

- 1 Diffusori multi 12  
Diffusers multi 12  
Diffuseurs multi 12  
Luftverteiler multi 12  
Difusores multi 12
- 2 Canalizzazione ø60 mm  
Ducting ø60 mm  
Canalisation ø60 mm  
Kanalisierung ø60 mm  
Canalización ø60 mm
- 3 Motore tra camino e diffusore  
Motor positioned between the fireplace and diffuser  
Moteur positionné entre la cheminée et le diffuseur  
Motor zwischen kaminofen Und luftverteiler  
Motor posicionado entre chimenea y difusor

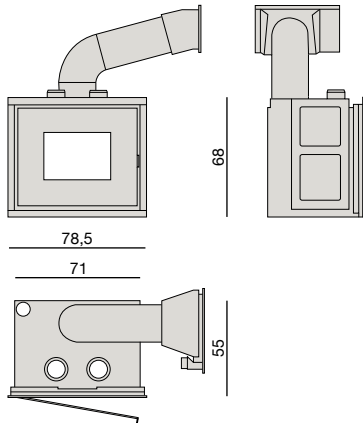

### COMFORT AIR

<b>POWER<sub>max</sub></b>	10,5 - 9.030 [kW-kcal/h]
<b>POWER<sub>min</sub></b>	2,7 - 2.322 [kW-kcal/h]
	92,2 / 95,8 [%]
	20 + 15 [l]
	pellet Ø 6-8 x 3±40 [mm]
	~ 0,6 / ~ 2,2 [kg/h]
	39 / 11 [h]
	226/40 - 258/35 - 301/30 [m <sup>3</sup> ]
	8 [cm]
	170 [kg]
	170 [°C]
	8,9 [g/s]



EN 14785

BImSchV Stufe 2

ART. 15a B-VG 2015

REGENSBURGER/

AACHENER/

MÜNCHENER BSiv



# Vivo 80 Hydro

**IL CAMNO A PELLET CHE SCALDA I TERMOSIFONI DI CASA  
THE PELLET FIREPLACE THAT HEATS THE HOUSE RADIATORS  
LA CHEMINÉE À PELLETS QUI CHAUFFE LES RADIATEURS DE LA MAISON  
DER PELLETKAMIN, DER DIE HEIZKÖRPER IM HAUS ERWÄRMT  
LA CHIMENEA DE PELLET QUE CALIENTA LOS TERMOSIFONES DE CASA**

**POSSIBILITÀ DI AVERE UNA GESTIONE  
AUTOMATICA E PROGRAMMABILE.**

(cronotermostato wireless in opzione per la gestione della temperatura ambiente).

**THE OPPORTUNITY TO HAVE AUTOMATIC  
AND PROGRAMMABLE MANAGEMENT.**

(Optional wireless timed thermostat for room temperature control).

**POSSIBILITÉ D'AVOIR UNE GESTION  
AUTOMATIQUE ET PROGRAMMABLE.**

(Chrono-thermostat sans fil en option pour la gestion de la température ambiante).

**MÖGLICHKEIT EINER AUTOMATISCHEN  
UND PROGRAMMIERBAREN REGELUNG.**

(Optionaler Wireless-Chronothermostat für die Einstellung der Raumtemperatur).

**POSIBILIDAD DE GESTIÓN AUTOMÁTICA Y  
PROGRAMABLE.**

(Cronotermostato inalámbrico opcional para gestionar la temperatura ambiente).

**CALDO IN TUTTA LA CASA CON I  
TERMOSIFONI GIA' PRESENTI.**

**HEAT THROUGHOUT THE HOME USING  
EXISTING RADIATORS.**

**DE LA CHALEUR DANS TOUTE LA MAISON  
AVEC LES RADIATEURS DÉJÀ EXISTANTS.**

**WÄRME IM GANZEN HAUS DURCH DIE  
SCHON VORHANDENEN HEIZKÖRPER.**

**CALOR EN TODA LA CASA CON LOS  
RADIADORES YA PRESENTES.**

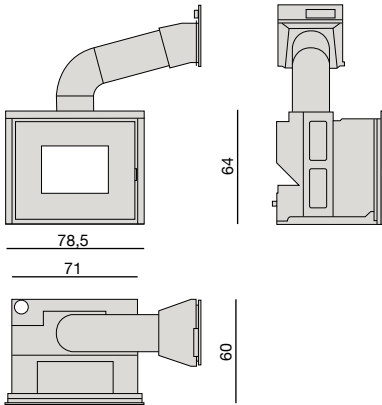

### HYDRO

<b>POWER max</b>	16,9 - 14,534 water 14,2 - 12.212 [kW-kcal/h]
<b>POWER min</b>	4,9 - 4,214 water 3,5 - 3.010 [kW-kcal/h]
	90,1 / 95,2 [%]
	20 + 15 [l]
	pellet Ø 6-8 x 3±40 [mm]
	~ 1 / ~ 3,6 [kg/h]
	23 / 7 [h]
	363/40 - 415/35 - 484/30 [m3]
	8 [cm]
	160 [kg]
	150 [°C]
	12,5 [g/s]



EN 14785  
UZ-37  
BlmSchV Stufe 2  
ART. 15a B-VG 2015  
REGENSBURGER/  
AACHENER/  
MÜNCHENER BSV



Conto Termico  
BAFA



# Vivo 85 Hydro

IL CAMINO A PELLETT HYDRO ANCORA PIÙ POTENTE  
THE EVEN MORE POWERFUL HYDRO PELLETT FIREPLACE  
LA CHEMINÉE À PELLETS HYDRO ENCORE PLUS PUISSANTE  
DER NOCH LEISTUNGSFÄHIGERE PELLETTKAMIN HYDRO  
LA CHIMENEA DE PELLETT HYDRO TODAVÍA MÁS POTENTE

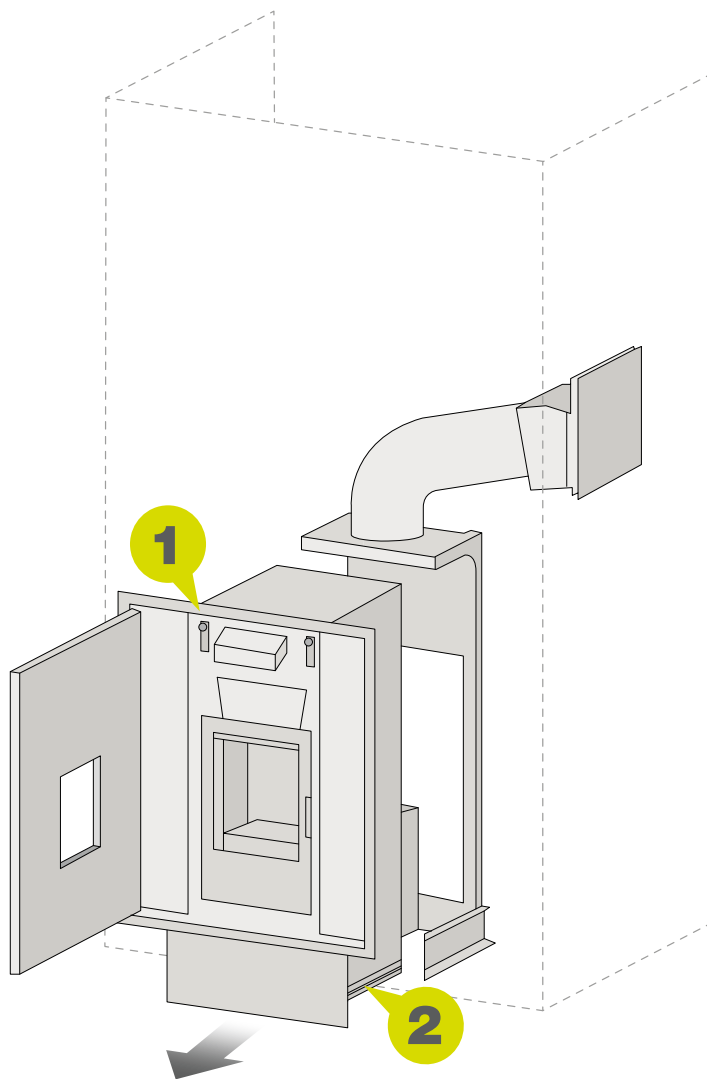

**1**

\_Accesso diretto ai turbolatori per manutenzione ordinaria.  
\_Direct access to turbulators for routine maintenance.  
\_Accès direct aux turbulateurs pour l'entretien ordinaire.  
\_Direkter Zugang zu den Turbulatoren für die regelmäßige Wartung.  
\_Acceso directo a los turbuladores para el mantenimiento ordinario.

**2**

\_Pratico sistema di estrazione su binari per agevolare la manutenzione straordinaria.  
\_Convenient extraction system on tracks to make extraordinary maintenance easier.  
\_Système pratique d'extraction sur rails pour faciliter l'entretien extraordinaire.  
\_Praktisches Entnahmesystem auf Schienen, um die außergewöhnliche Wartung einfacher zu gestalten.  
\_Práctico sistema de extracción en binarios para facilitar el mantenimiento extraordinario.

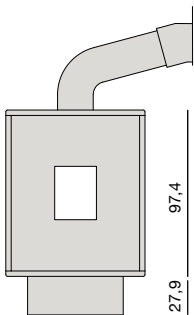

81,5

97,4

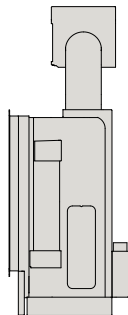

70

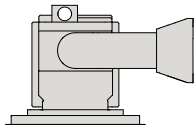

### HYDRO \*\*\*

**POWER max** 22,3-19.178 [kW-kcal/h]  
water 18-15.480[kW-kcal/h]

**POWER min** 4,4-3.784 [kW-kcal/h]  
water 3-2.580[kW-kcal/h]



92,5 / 95  
[%]



44  
[l]



pellet Ø 6-8 x 3÷40  
[mm]



~ 0,9 / ~ 4,9  
[kg/h]



~ 28 / ~ 5  
[h]



481/40 - 550/35 - 642/30  
[m³]



8  
[cm]



190  
[kg]



160  
[°C]



12,6  
[g/s]

CE

EN 14785

BlmSchV Stufe 2

ART. 15a B-VG 2015

REGENSBURGER/  
AACHENER/  
MÜNCHENER BStV



Conto Termico  
BAFA



# Boxtherm

**L'INSERTO PROGRAMMABILE PER I VECCHI FOCOLARI CHE NON FUNZIONANO E/O NON SCALDANO.**

**THE PROGRAMMABLE INSERT FOR OLD FIRE BOXES NOT WORKING AND/OR HEATING.**

**L'INSERT PROGRAMMABLE POUR LES FOYERS ANCIENS QUI NE FONCTIONNENT PAS ET/OU NE CHAUFFENT PAS.**

**DER PROGRAMMIERBARE EINSATZ FÜR ALTE FEUERSTELLEN, DIE NICHT MEHR FUNKTIONIEREN UND/ODER NICHT HEIZEN.**

**EL INSERTABLE PROGRAMABLE PARA LOS VIEJOS HOGARES QUE NO FUNCIONAN Y/O NO CALIENTAN.**

## **RISPARMIO DAL 60% ALL'80%.**

Grazie agli alti rendimenti della tecnologia pellet, si possono ottenere risparmi dal 60% all'80% rispetto ad un tradizionale focolare aperto alimentato a legna.

## **60% TO 80% SAVINGS.**

Thanks to the high yield from pellet technology, you can gain savings from 60% to 80% respect to a traditional open fire box burning wood.

## **ÉCONOMIE DE 60% À 80%.**

Grâce aux rendements élevés de la technologie pellet, on peut obtenir une économie entre 60% et 80% par rapport à un foyer ouvert traditionnel alimenté à bois.

## **EINE EINSPARUNG VON 60% BIS 80%.**

Dank dem hohen Wirkungsgrad der Pellet-Technologie können Einsparungen von 60% bis 80% gegenüber einer herkömmlichen Feuerstelle, die mit Holz befüllt wird, erzielt werden.

## **AHORRO DE ENTRE EL 60% Y EL 80%.**

Gracias a los altos rendimientos de la tecnología de pellets, se pueden obtener ahorros de entre el 60% y el 80% respecto a un hogar abierto tradicional alimentado con leña.

## **CORPO MACCHINA ESTRAIBILE.**

Tutto il corpo macchina è facilmente estraibile per una comoda e più pratica manutenzione periodica dello scarico fumario.

## **EXTRACTABLE MACHINE BODY.**

The whole machine body can be easily extracted for convenient and practical periodic maintenance of the smoke outlet.

## **APPAREIL EXTRAITABLE.**

Cet appareil est facilement extractible pour un commode et pratique entretien périodique du conduit de sortie des fumées.

## **HERAUSZIEH-BARES GERÄTEGEHÄUSE.**

Das gesamte Gehäuse des Geräts lässt sich einfach herausziehen, für eine bequeme und praktischere regelmäßige Wartung des Rauchabzugs.

## **CUERPO DE LA MÁQUINA EXTRAÍBLE.**

Todo el cuerpo de la máquina se puede extraer fácilmente para un mantenimiento periódico de la salida de humos cómodo y más práctico.

## **INSTALLAZIONE NON INVASIVA.**

Per chi non ha la possibilità di sfondare la cappa, Boxtherm prevede l'uscita aria calda frontale e il caricamento pellet attraverso un comodo cassetto estraibile dalla parte frontale.

## **NON-INVASIVE INSTALLATION.**

For those not able to break through the hood, Boxtherm foresees frontal hot air output and pellet loading through a handy extractable drawer in the frontal part.

## **INSTALLATION NON INVASIVE.**

Pour ceux qui n'ont pas la possibilité de percer la hotte, Boxtherm prévoit la sortie frontale de l'air chaud et le chargement du pellet à travers un pratique tiroir extractible sur la partie frontale.

## **GERINGE INSTALLATIONSARBEITEN.**

Wer nicht die Möglichkeit besitzt, die Abzugshaube einzubauen, für den sieht Boxtherm den vorderen Warm-luftaustritt und die Pellet-Zuführung über einen bequemen herausziehbaren Kasten an der Vorderseite vor.

## **INSTALACIÓN NO INVASIVA.**

Para quien no tiene la posibilidad de desfondar la campana, Boxtherm prevé la salida de aire caliente por el frente y la carga de los pellets a través de un cómodo cajón extraíble desde la parte frontal.



**BOXTHERM 60**



**BOXTHERM 70**

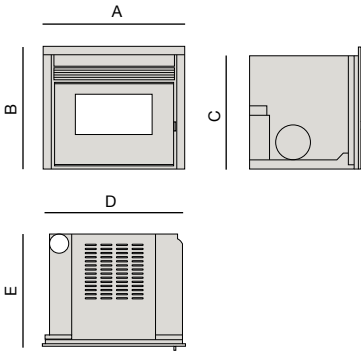

	A	B	C	D	E
60	59	55	50,8	56,5	45
70	70	60	56	67,5	55



	<b>BOXTHERM 60</b>	<b>BOXTHERM 70</b>
<b>POWER max</b>	6,1 - 5.246 [kW-kcal/h]	8,8 - 7.568 [kW-kcal/h]
<b>POWER min</b>	2,4 - 2064 [kW-kcal/h]	2,6 - 2.236 [kW-kcal/h]
	91,7 / 93,0 [%]	92,7 / 95,9 [%]
	13 [l]	27 [l]
	pellet Ø 6-8 x 3÷40 [mm]	pellet Ø6-8 x 3÷40 [mm]
	~ 0,6 / ~ 1,25 [kg/h]	~ 0,6 / ~ 1,8 [kg/h]
	~ 14 / ~ 7 [h]	~ 26 / ~ 9 [h]
	131/40 - 150/35 175/30 [m³]	189/40 - 216/35 252/30 [m³]
	8 [cm]	8 [cm]
	80 [kg]	135 [kg]
	150 [°C]	150 [°C]
	6,5 [g/s]	7,4 [g/s]



EN 14785

UZ-37

BlmSchV Stufe 2

ART. 15a B-VG 2015

REGENSBURGER/  
AACHENER/  
MÜNCHENER BSTV



Conto Termico





# Curve



## COMFORT AIR

**POWER<sub>max</sub>** 8 - 6.880 [kW-kcal/h]

**POWER<sub>min</sub>** 2,4 - 2.064 [kW-kcal/h]

90,3 / 92,1 [%]



32 [l]

pellet Ø 6-8 x 3÷40 [mm]

~ 0,6 / ~ 1,8 [kg/h]

~ 40 / ~ 13 [h]

172/40 - 196/35 - 229/30 [m³]



8 [cm]



170 [kg]



170 [°C]



5,2 [g/s]

# Mood



## COMFORT AIR

**POWER<sub>max</sub>** 8 - 6.880 [kW-kcal/h]

**POWER<sub>min</sub>** 2,4 - 2.064 [kW-kcal/h]

90,3 / 92,1 [%]



32 [l]

pellet Ø 6-8 x 3÷40 [mm]

~ 0,6 / ~ 1,8 [kg/h]

~ 40 / ~ 13 [h]

172/40 - 196/35 - 229/30 [m³]



8 [cm]



132 [kg]



170 [°C]



5,2 [g/s]

CE

EN 14785

BImSchV Stufe 2

ART. 15a B-VG 2015

REGENSBURGER/  
AACHENER/  
MÜNCHENER BStV



Conto Termico

102\_White

113\_Warm grey

107\_Black

105\_Bordeaux

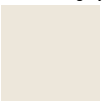
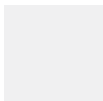

CE

EN 14785

BImSchV Stufe 2

ART. 15a B-VG 2015

REGENSBURGER/  
AACHENER/  
MÜNCHENER BStV



Conto Termico

313\_Silver

303\_Black

305\_Bronze



# Halo



## AIR

POWER max	8 - 6.880 [kW-kcal/h]
POWER min	2,4 - 2.064 [kW-kcal/h]
	90,3 / 92,1 [%]
	32 [l]
	pellet Ø 6-8 x 3÷40 [mm]
	~ 0,6 / ~ 1,8 [kg/h]
	~ 40 / ~ 13 [h]
	172/40 - 196/35 - 229/30 [m³]
	8 [cm]
	127 [kg]
	170 [°C]
	5,2 [g/s]

# Toba



## AIR COMFORT AIR

## HYDRO \*

POWER max	8 - 6.880 [kW-kcal/h]	22,3-19.178 [kW-kcal/h] water 18-15.480[kW-kcal/h]
POWER min	2,4 - 2.064 [kW-kcal/h]	4,4-3.784 [kW-kcal/h] water 3-2.580[kW-kcal/h]
	91,7 / 94,1 [%]	92,5 / 95 [%]
	Air 37 [l] Comfort Air 35 [l]	38 [l]
	pellet Ø 6-8 x 3÷40 [mm]	pellet Ø 6-8 x 3÷40 [mm]
	~ 0,6 / ~ 1,8 [kg/h]	~ 0,9 / ~ 4,9 [kg/h]
	~ 40 / ~ 13 [h]	~ 27 / ~ 5 [h]
	172/40 - 196/35 - 229/30 Comfort Air 197 [m³]	481/40 - 550/35 - 642/30 [m³]
	8 [cm]	8 [cm]
	140 [kg]	165 [kg]
	170 [°C]	160 [°C]
	6,6 [g/s]	12,6 [g/s]



EN 14785  
BlmSchV Stufe 2  
ART. 15a B-VG 2015  
REGENSBURGER/  
AACHENER/  
MÜNCHENER BStV



Conto Termico



EN 14785  
BlmSchV Stufe 2  
ART. 15a B-VG 2015  
REGENSBURGER/  
AACHENER/  
MÜNCHENER BStV



HTSMCS1507 - HYDRO



Conto Termico  
UZ-37 (Air / Comfort Air)  
BAFA (Hydro)

315\_Aluminium 313\_Silver 303\_Black 304\_Bordeaux



102\_White 107\_Black 105\_Bordeaux 248\_Sandstone 202\_Soapstone 118\_Skin



# Klin



## COMFORT AIR \*\*\*

POWER <sub>max</sub>	8 - 6.880 [kW-kcal/h]
POWER <sub>min</sub>	2,4 - 2.064 [kW-kcal/h]
	90,1 / 90,7 [%]
	35 [l]
	pellet Ø 6-8 x 3÷40 [mm]
	~ 0,6 / ~ 1,8 [kg/h]
	~ 38 / ~ 13 [h]
	172/40 - 197/35 - 229/30 [m³]
	8 [cm]
	200 [kg]
	170 [°C]
	7 [g/s]

CE

EN 14785

BlmSchV Stufe 2

ART. 15a B-VG 2015

REGENSBURGER/  
AACHENER/  
MÜNCHENER BStV



Conto Termico

303\_Black 240\_Serpentino



# Tilda



## COMFORT AIR \*\*\*

POWER <sub>max</sub>	10,1 - 8.686 [kW-kcal/h]
POWER <sub>min</sub>	2,9 - 2.494 [kW-kcal/h]
	90,3 / 92,9 [%]
	35 [l]
	pellet Ø 6-8 x 3÷40 [mm]
	~ 0,7 / ~ 2,2 [kg/h]
	~ 33 / ~ 11 [h]
	217/40 - 248/35 - 290/30 [m³]
	8 [cm]
	180 [kg]
	180 [°C]
	8 [g/s]

CE

EN 14785

BlmSchV Stufe 2

ART. 15a B-VG 2015

REGENSBURGER/  
AACHENER/  
MÜNCHENER BStV



Conto Termico

303\_Black



# Aike



## AIR OYSTER

## COMFORT AIR \*\*\*

POWER <sub>max</sub>	8 - 6.880 [kW-kcal/h]
POWER <sub>min</sub>	2,4 - 2.064 [kW-kcal/h]
	91,6 / 95,0 [%]
	36 [l]
	pellet Ø 6-8 x 3÷40 [mm]
	~ 0,5 / ~ 1,8 [kg/h]
	~ 52 / ~ 14 [h]
	172/40 - 197/35 - 229/30 [m³]
	8 [cm]
	180 [kg]
	160 [°C]
	4,9 [g/s]

POWER <sub>max</sub>	8 - 6.880 [kW-kcal/h]
POWER <sub>min</sub>	2,4 - 2.064 [kW-kcal/h]
	90,1 / 90,7 [%]
	35 [l]
	pellet Ø 6-8 x 3÷40 [mm]
	~ 0,6 / ~ 1,8 [kg/h]
	~ 38 / ~ 13 [h]
	172/40 - 197/35 - 229/30 [m³]
	8 [cm]
	180 [kg]
	170 [°C]
	7 [g/s]

# Sagar



## AIR

POWER <sub>max</sub>	8 - 6.880 [kW-kcal/h]
POWER <sub>min</sub>	2,4 - 2.064 [kW-kcal/h]
	91,7 / 94,1 [%]
	37 [l]
	pellet Ø 6-8 x 3÷40 [mm]
	~ 0,6 / ~ 1,8 [kg/h]
	~ 40 / ~ 13 [h]
	172/40 - 196/35 - 229/30 [m³]
	8 [cm]
	140 [kg]
	170 [°C]
	6,6 [g/s]

## CE

EN 14785  
BlmSchV Stufe 2  
ART. 15a B-VG 2015  
REGENSBURGER/  
AACHENER/  
MÜNCHENER BStV



OYSTER



Conto Termico

## CE

EN 14785  
BlmSchV Stufe 2  
ART. 15a B-VG 2015  
REGENSBURGER/  
AACHENER/  
MÜNCHENER BStV



Conto Termico  
UZ-37

303\_Black



102\_White

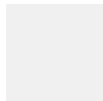

103\_White  
leaves



202\_Soapstone



# Lam



## NATURAL

**POWER<sub>max</sub>** 8 - 6.880 [kW-kcal/h]

**POWER<sub>min</sub>** 2,4 - 2.064 [kW-kcal/h]

93 / 93 [%]

35 [l]

pellet Ø 6-8 x 3÷40 [mm]

~ 0,8 / ~ 1,8 [kg/h]

~ 28 / ~ 13 [h]

172/40 - 197/35 - 229/30 [m³]

8 [cm]

135 (165 Serpentino) [kg]

160 [°C]

6,9 [g/s]

# Cap



## NATURAL

**POWER<sub>max</sub>** 8 - 6.880 [kW-kcal/h]

**POWER<sub>min</sub>** 2,4 - 2.064 [kW-kcal/h]

93 / 93 [%]

35 [l]

pellet Ø 6-8 x 3÷40 [mm]

~ 0,8 / ~ 1,8 [kg/h]

~ 28 / ~ 13 [h]

172/40 - 197/35 - 229/30 [m³]

8 [cm]

135 [kg]

160 [°C]

6,9 [g/s]

CE

EN 14785

BlmSchV Stufe 2

ART. 15a B-VG 2015

REGENSBURGER/  
AACHENER/  
MÜNCHENER BStV



Conto Termico  
UZ-37

CE

EN 14785

BlmSchV Stufe 2

ART. 15a B-VG 2015

REGENSBURGER/  
AACHENER/  
MÜNCHENER BStV



Conto Termico  
UZ-37

302\_White

303\_Black

304\_Bordeaux

240\_Serpentino 318\_Metal net

303\_Black

305\_Bronze



# Tray



## NATURAL

POWER <sub>max</sub>	8 - 6.880 [kW-kcal/h]
POWER <sub>min</sub>	2,4 - 2.064 [kW-kcal/h]
	93 / 93 [%]
	35 [l]
	pellet Ø 6-8 x 3÷40 [mm]
	~ 0,8 / ~ 1,8 [kg/h]
	~ 28 / ~ 13 [h]
	172/40 - 197/35 - 229/30 [m <sup>2</sup> ]
	8 [cm]
	135 [kg]
	160 [°C]
	6,9 [g/s]



EN 14785

BlmSchV Stufe 2

ART. 15a B-VG 2015

REGENSBURGER/  
AACHENER/  
MÜNCHENER BStV



Conto Termico  
UZ-37

303\_Black

305\_Bronze

240\_Serpentino



# Star



## AIR

POWER <sub>max</sub>	8 - 6.880 [kW-kcal/h]
POWER <sub>min</sub>	2,4 - 2.064 [kW-kcal/h]
	90,1 / 90,7 [%]
	35 [l]
	pellet Ø 6-8 x 3÷40 [mm]
	~ 0,6 / ~ 1,8 [kg/h]
	~ 38 / ~ 13 [h]
	172/40 - 197/35 - 229/30 [m <sup>2</sup> ]
	8 [cm]
	124 [kg]
	170 [°C]
	7 [g/s]



EN 14785

BlmSchV Stufe 2

ART. 15a B-VG 2015

REGENSBURGER/  
AACHENER/  
MÜNCHENER BStV



Conto Termico

102\_White

107\_Black

109\_Sand

105\_Bordeaux

240\_Serpentino

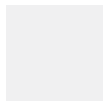

# Suite

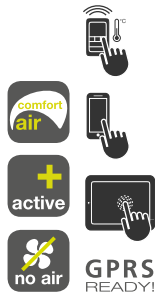

	AIR	COMFORT AIR	HYDROMATIC 16	HYDROMATIC 24
<b>POWER<sub>max</sub></b>	10,1 - 8.686 [kW-kcal/h]	12,1 - 10.406 [kW-kcal/h]	16,1-13.846 [kW-kcal/h] water 12,8-11.008[kW-kcal/h]	23,9-20.554 [kW-kcal/h] water 18.6-15.996[kW-kcal/h]
<b>POWER<sub>min</sub></b>	2,9 - 2.494 [kW-kcal/h]	3,3 - 2.838 [kW-kcal/h]	4,3-3.698 [kW-kcal/h] water 2,9-2.494[kW-kcal/h]	4,3-3.698 [kW-kcal/h] water 2,9-2.494[kW-kcal/h]
	90,3 / 92,9 [%]	90,5 / 95,1 [%]	93,6 / 95,4 [%]	91,9 / 95,4 [%]
	42 [l]	42 [l]	48 [l]	48 [l]
	pellet Ø 6-8 x 3÷40 [mm]	pellet Ø 6-8 x 3÷40 [mm]	pellet Ø 6-8 x 3÷40 [mm]	pellet Ø 6-8 x 3÷40 [mm]
	~ 0,7 / ~ 2,2 [kg/h]	~ 0,8 / ~ 2,7 [kg/h]	~ 0,9 / ~ 3,3 [kg/h]	~ 0,9 / ~ 4,8 [kg/h]
	~ 39 / ~ 13 [h]	~ 34 / ~ 10 [h]	~ 35 / ~ 9,5 [h]	~ 35 / ~ 6,5 [h]
	217/40 - 248/35 - 290/30 [m³]	260/40 - 297/35 - 347/30 [m³]	348/40 - 398/35 - 465/30 [m³]	496/40 - 567/35 - 662/30 [m³]
	8 [cm]	8 [cm]	8 [cm]	8 [cm]
	160 [kg]	164 [kg]	197 [kg]	197 [kg]
	180 [°C]	190 [°C]	100 [°C]	140 [°C]
	8 [g/s]	9 [g/s]	10,9 [g/s]	12 [g/s]

CE

EN 14785

BlmSchV Stufe 2

ART. 15a B-VG 2015

REGENSBURGER/  
AACHENER/  
MÜNCHENER BStV



Conto Termico

110\_Salt and pepper



111\_Old amber



105\_Bordeaux



# Club



	AIR	COMFORT AIR	HYDROMATIC 16	HYDROMATIC 24
<b>POWER<sub>max</sub></b>	10,1 - 8.686 [kW-kcal/h]	12,1 - 10.406 [kW-kcal/h]	16,1-13.846 [kW-kcal/h] water 12,8-11.008[kW-kcal/h]	23,9-20.554 [kW-kcal/h] water 18.6-15.996[kW-kcal/h]
<b>POWER<sub>min</sub></b>	2,9 - 2.494 [kW-kcal/h]	3,3 - 2.838 [kW-kcal/h]	4,3-3.698 [kW-kcal/h] water 2,9-2.494[kW-kcal/h]	4,3-3.698 [kW-kcal/h] water 2,9-2.494[kW-kcal/h]
	90,3 / 92,9 [%]	90,5 / 95,1 [%]	93,6 / 95,4 [%]	91,9 / 95,4 [%]
	42 [l]	42 [l]	48 [l]	48 [l]
	pellet Ø 6-8 x 3÷40 [mm]	pellet Ø 6-8 x 3÷40 [mm]	pellet Ø 6-8 x 3÷40 [mm]	pellet Ø 6-8 x 3÷40 [mm]
	~ 0,7 / ~ 2,2 [kg/h]	~ 0,8 / ~ 2,7 [kg/h]	~ 0,9 / ~ 3,3 [kg/h]	~ 0,9 / ~ 4,8 [kg/h]
	~ 39 / ~ 13 [h]	~ 34 / ~ 10 [h]	~ 35 / ~ 9,5 [h]	~ 35 / ~ 6,5 [h]
	217/40 - 248/35 - 290/30 [m³]	260/40 - 297/35 - 347/30 [m³]	348/40 - 398/35 - 465/30 [m³]	496/40 - 567/35 - 662/30 [m³]
	8 [cm]	8 [cm]	8 [cm]	8 [cm]
	160 [kg]	164 [kg]	197 [kg]	197 [kg]
	180 [°C]	190 [°C]	100 [°C]	140 [°C]
	8 [g/s]	9 [g/s]	10,9 [g/s]	12 [g/s]

CE

EN 14785  
BlmSchV Stufe 2  
ART. 15a B-VG 2015  
REGENSBURGER/  
AACHENER/  
MÜNCHENER BStV



Conto Termico

102\_White

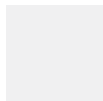

107\_Black



109\_Sand



105\_Bordeaux





# Musa

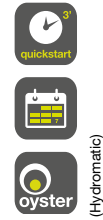

	AIR	COMFORT AIR 12	COMFORT AIR 14 <sup>®</sup> ***	HYDROMATIC 16
<b>POWER<sub>max</sub></b>	10,1 - 8.686 [kW-kcal/h]	12,1 - 10.406 [kW-kcal/h]	14 - 12.040 [kW-kcal/h]	16,1-13.846 [kW-kcal/h] water 12,8-11.008[kW-kcal/h]
<b>POWER<sub>min</sub></b>	2,9 - 2.494 [kW-kcal/h]	3,3 - 2.838 [kW-kcal/h]	4 - 3.440 [kW-kcal/h]	4,3-3.698 [kW-kcal/h] water 2,9-2.494[kW-kcal/h]
	90,3 / 92,9 [%]	90,5 / 95,1 [%]	> 90% [%]	93,6 / 95,4 [%]
	42 [l]	42 [l]	42 [l]	48 [l]
	pellet Ø 6-8 x 3÷40 [mm]	pellet Ø 6-8 x 3÷40 [mm]	pellet Ø 6-8 x 3÷40 [mm]	pellet Ø 6-8 x 3÷40 [mm]
	~ 0,7 / ~ 2,2 [kg/h]	~ 0,8 / ~ 2,7 [kg/h]	~ 0,9 / ~ 3,0 [kg/h]	~ 0,9 / ~ 3,3 [kg/h]
	~ 39 / ~ 13 [h]	~ 34 / ~ 10 [h]	~ 35 / ~ 10 [h]	~ 35 / ~ 9,5 [h]
	217/40 - 248/35 - 290/30 [m³]	260/40 - 297/35 - 347/30 [m³]	301/40 - 344/35 - 401/30 [m³]	348/40 - 398/35 - 465/30 [m³]
	8 [cm]	8 [cm]	8 [cm]	8 [cm]
	138 [kg]	142 [kg]	142 [kg]	197 [kg]
	180 [°C]	190 [°C]	200 [°C]	100 [°C]
	8 [g/s]	9 [g/s]	11 [g/s]	10,9 [g/s]

CE

EN 14785

BlmSchV Stufe 2

ART. 15a B-VG 2015

REGENSBURGER/  
AACHENER/  
MÜNCHENER BStV



Conto Termico

302\_White

313\_Silver

308\_Dark

304\_Bordeaux

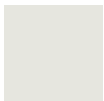

## ⊕ COMFORT AIR 14

\_Data la potenza elevata, si sconsiglia l'utilizzo della stufa senza canalizzazione dell'aria calda.

\_In view of its high power, use of the stove without hot air ducting is recommended against.

\_Debido a la potencia elevada, se desaconseja usar la estufa sin canalización del aire caliente.

\_Compte tenu de la puissance élevée, il est déconseillé d'utiliser le poêle sans canalisation de l'air chaud.

\_Auf Grund der hohen Leistung wird von einer Verwendung des Ofens ohne Kanalisierung der Warmluft abgeraten.

# Ego



GPRS  
READY!

## HYDROMATIC 24

23,9-20.554 [kW-kcal/h]  
water 18.6-15.996[kW-kcal/h]

4,3-3.698 [kW-kcal/h]  
water 2,9-2.494[kW-kcal/h]

91,9 / 95,4  
[%]

48  
[l]

pellet Ø 6-8 x 3÷40  
[mm]

~ 0,9 / ~ 4,8  
[kg/h]

~ 35 / ~ 6,5  
[h]

496/40 - 567/35 - 662/30  
[m³]

8  
[cm]

197  
[kg]

140  
[°C]

12  
[g/s]

## AIR AIR OYSTER

POWER  
max 8 - 6.880  
[kW-kcal/h]

POWER  
min 2,4 - 2.064  
[kW-kcal/h]



90,1 / 90,7 [%]  
Oyster 91,6 / 95,0



35  
[l]



pellet Ø 6-8 x 3÷40  
[mm]



~ 0,6 / ~ 1,8 [kg/h]  
Oyster ~ 0,5 / ~ 1,8



~ 38 / ~ 13 [h]  
Oyster ~ 44 / ~ 13



172/40 - 197/35 - 229/30  
[m³]



8  
[cm]



111  
[kg]



Air 170 [°C]  
Oyster 160 [°C]



Air 7 [g/s]  
Oyster 4,9 [g/s]

## COMFORT AIR

10,1 - 8.686  
[kW-kcal/h]

2,9 - 2.494  
[kW-kcal/h]

90,3 / 92,9  
[%]

35  
[l]

pellet Ø 6-8 x 3÷40  
[mm]

~ 0,7 / ~ 2,2  
[kg/h]

~ 33 / ~ 11  
[h]

217/40 - 248/35 - 290/30  
[m³]

8  
[cm]

113  
[kg]

180  
[°C]

8  
[g/s]



EN 14785

BlmSchV Stufe 2

ART. 15a B-VG 2015

REGENSBURGER/  
AACHENER/  
MÜNCHENER BStV



Conto Termico

302\_White

313\_Silver

308\_Dark

304\_Bordeaux

311\_Inox  
no touch

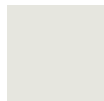

# Kaika



	AIR	AIR OYSTER
<b>POWER<sub>max</sub></b>	6 - 5.160 [kW-kcal/h]	5,4 - 4.644 [kW-kcal/h]
<b>POWER<sub>min</sub></b>	2,1 - 1.720 [kW-kcal/h]	2,3 - 1.978 [kW-kcal/h]
	92,8 / 94 [%]	93,4 / 94 [%]
	16 [l]	16 [l]
	pellet Ø 6-8 x 3÷40 [mm]	pellet Ø 6-8 x 3÷40 [mm]
	~ 0,5 / ~ 1,45 [kg/h]	~ 0,5 / ~ 1,2 [kg/h]
	~ 21 / ~ 7 [h]	~ 21 / ~ 9 [h]
	129/40 - 147/35 - 172/30 [m³]	116/40 - 133/35 - 155/30 [m³]
	8 [cm]	8 [cm]
	120 [kg]	120 [kg]
	160 [°C]	115 [°C]
	6 [g/s]	3,8 [g/s]

CE

EN 14785

BImSchV Stufe 2 (only Kaika)

ART. 15a B-VG 2015

REGENSBURGER/  
AACHENER/  
MÜNCHENER BStV



OYSTER



Flamme  
VERTE

Avec le concours de l'ADEME



DIBt - Allgemeine  
bauaufsichtliche Zulassung  
(Oyster)  
Conto Termico

302\_White

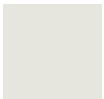

303\_Black

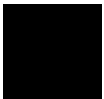

315\_Aluminium



314\_Red



304\_Bordeaux



# Face



	AIR
<b>POWER<sub>max</sub></b>	6 - 5.160 [kW-kcal/h]
<b>POWER<sub>min</sub></b>	2,1 - 1.720 [kW-kcal/h]
	92,8 / 94 [%]
	16 [l]
	pellet Ø 6-8 x 3÷40 [mm]
	~ 0,5 / ~ 1,45 [kg/h]
	~ 21 / ~ 7 [h]
	129/40 - 147/35 - 172/30 [m³]
	8 [cm]
	120 [kg]
	160 [°C]
	6 [g/s]

CE

EN 14785

BImSchV Stufe 2

ART. 15a B-VG 2015

REGENSBURGER/  
AACHENER/  
MÜNCHENER BStV



Flamme  
VERTE

Avec le concours de l'ADEME



Conto Termico

313\_Silver



308\_Dark



304\_Bordeaux



# Amy



**AIR**

**POWER**  
max 6,2 - 5.332  
[kW-kcal/h]

**POWER**  
min 2,1 - 1.806  
[kW-kcal/h]

91,1 / 92,0  
[%]

24  
[l]

pellet Ø 6-8 x 3÷40  
[mm]

~ 0,6 / ~ 1,45  
[kg/h]

~ 28 / ~ 11,5  
[h]

135/40 - 155/35 - 180/30  
[m³]

8  
[cm]

90  
[kg]

170  
[°C]

5,2  
[g/s]

# Giò



**AIR**

**POWER**  
max 8,1 - 6.966  
[kW-kcal/h]

**POWER**  
min 2,4 - 2.064  
[kW-kcal/h]

90 / 94,5  
[%]

30  
[l]

pellet Ø 6-8 x 3÷40  
[mm]

~ 0,7 / ~ 1,7  
[kg/h]

~ 26 / ~ 11,5  
[h]

174/40 - 199/35 - 232/30  
[m³]

8  
[cm]

100  
[kg]

190  
[°C]

6,6  
[g/s]

**CE**

EN 14785

BlmSchV Stufe 2

ART. 15a B-VG 2015

REGENSBURGER/  
AACHENER/  
MÜNCHENER BStV



Conto Termico  
BAFA

**CE**

EN 14785

BlmSchV Stufe 2

ART. 15a B-VG 2015

REGENSBURGER/  
AACHENER/  
MÜNCHENER BStV



Conto Termico

302\_White

313\_Silver

308\_Dark

304\_Bordeaux



302\_White

308\_Dark

304\_Bordeaux

315\_Aluminium

313\_Silver



# Maggie



**GPRS  
READY!**

**CANALIZZABILE \*\*\*  
DUCTABLE \*\*\*  
CANALISABLE \*\*\*  
KANALISIERBAR \*\*\*  
CANALIZABLE \*\*\***

**POWER<sub>max</sub>** 10,1 - 8.686  
[kW-kcal/h]

**POWER<sub>min</sub>** 2,9 - 2.494  
[kW-kcal/h]

90,3 / 92,9  
[%]

35  
[l]

pellet Ø 6-8 x 3÷40  
[mm]

~ 0,7 / ~ 2,2  
[kg/h]

~ 33 / ~ 11  
[h]

217/40 - 248/35 - 290/30  
[m³]

8  
[cm]

100  
[kg]

180  
[°C]

8  
[g/s]

# Cute



**GPRS  
READY!**

**AIR**

**POWER<sub>max</sub>** 7,6 - 6.536  
[kW-kcal/h]

**POWER<sub>min</sub>** 3,8 - 2.268  
[kW-kcal/h]

87,6 / 86,8  
[%]

20  
[l]

pellet Ø 6-8 x 3÷40  
[mm]

~ 0,9 / ~ 1,8  
[kg/h]

~ 15 / ~ 7  
[h]

163/40 - 187/35 - 218/30  
[m³]

10/8  
[cm]

130  
[kg]

172  
[°C]

6,5  
[g/s]

**CE**

EN 14785

BlmSchV Stufe 2

ART. 15a B-VG 2015

REGENSBURGER/  
AACHENER/  
MÜNCHENER BStV



Conto Termico

308\_Dark

302\_White

304\_Bordeaux



**CE**

EN 14785

BlmSchV Stufe 2

ART. 15a B-VG 2015

REGENSBURGER/  
AACHENER/  
MÜNCHENER BStV



Conto Termico

303\_Black



# Thema



## AIR

POWER <sub>max</sub>	7,6 - 6.536 [kW-kcal/h]
POWER <sub>min</sub>	3,8 - 2.268 [kW-kcal/h]
	87,6 / 86,8 [%]
	20 [l]
	pellet Ø 6-8 x 3÷40 [mm]
	~ 0,9 / ~ 1,8 [kg/h]
	~ 15 / ~ 7 [h]
	163/40 - 187/35 - 218/30 [m³]
	10/8 [cm]
	130 [kg]
	172 [°C]
	6,5 [g/s]



EN 14785  
BlmSchV Stufe 2  
ART. 15a B-VG 2015  
REGENSBURGER/  
AACHENER/  
MÜNCHENER BStV



Conto Termico

102\_White    107\_Black    240\_Serpentino



# Decò

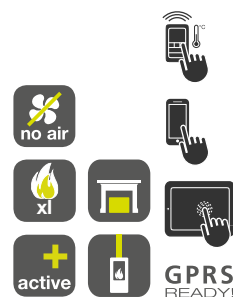

## AIR

POWER <sub>max</sub>	7,6 - 6.536 [kW-kcal/h]
POWER <sub>min</sub>	3,8 - 2.268 [kW-kcal/h]
	87,6 / 86,8 [%]
	20 [l]
	pellet Ø 6-8 x 3÷40 [mm]
	~ 0,9 / ~ 1,8 [kg/h]
	~ 15 / ~ 7 [h]
	163/40 - 187/35 - 218/30 [m³]
	10/8 [cm]
	185 [kg]
	172 [°C]
	6,5 [g/s]



EN 14785  
BlmSchV Stufe 2  
ART. 15a B-VG 2015  
REGENSBURGER/  
AACHENER/  
MÜNCHENER BStV



Conto Termico

501\_Smoke    502\_Green



# Tube



## COMFORT AIR

<b>POWER<sub>max</sub></b>	8 - 6.880 [kW-kcal/h]
<b>POWER<sub>min</sub></b>	2,4 - 2.064 [kW-kcal/h]
	91,7 / 94,1 [%]
	32 [l]
	pellet Ø 6-8 x 3÷40 [mm]
	~ 0,6 / ~ 1,8 [kg/h]
	~ 40 / ~ 13 [h]
	172/40 - 196/35 - 229/30 [m³]
	8 [cm]
	130 [kg]
	170 [°C]
	6,6 [g/s]

CE

EN 14785

BlmSchV Stufe 2

ART. 15a B-VG 2015

REGENSBURGER/  
AACHENER/  
MÜNCHENER BStV



Conto Termico  
UZ-37

317\_Silver dark 303\_Black 305\_Bronze



# Nima



## COMFORT AIR

<b>POWER<sub>max</sub></b>	11,5 - 9.890 [kW-kcal/h]
<b>POWER<sub>min</sub></b>	2,4 - 2.064 [kW-kcal/h]
	90,2 / 94,1 [%]
	44 [l]
	pellet Ø 6-8 x 3÷40 [mm]
	~ 0,6 / ~ 2,2 [kg/h]
	~ 48 / ~ 13 [h]
	247/40 - 283/35 - 330/30 [m³]
	8 [cm]
	160 [kg]
	190 [°C]
	9,9 [g/s]

CE

EN 14785

BlmSchV Stufe 2

ART. 15a B-VG 2015

REGENSBURGER/  
AACHENER/  
MÜNCHENER BStV



Conto Termico  
UZ-37

102\_White 113\_Warm gray 105\_Bordeaux 248\_Sandstone 240\_Serpentino



# Flair



## COMFORT AIR

**POWER**  
max 8 - 6.880  
[kW-kcal/h]

**POWER**  
min 3,2 - 2.752  
[kW-kcal/h]

87,8 / 93,6  
[%]

30  
[l]

pellet Ø 6-8 x 3÷40  
[mm]

~ 0,7 / ~ 1,8  
[kg/h]

~ 29 / ~ 11  
[h]

172/40 - 197/35 - 229/30  
[m³]

8  
[cm]

125  
[kg]

160  
[°C]

7  
[g/s]

# Flat

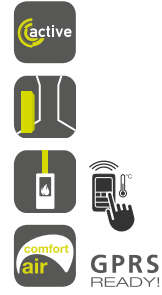

## COMFORT AIR

**POWER**  
max 8 - 6.880  
[kW-kcal/h]

**POWER**  
min 3,2 - 2.752  
[kW-kcal/h]

87,8 / 93,6  
[%]

30  
[l]

pellet Ø 6-8 x 3÷40  
[mm]

~ 0,7 / ~ 1,8  
[kg/h]

~ 29 / ~ 11  
[h]

172/40 - 197/35 - 229/30  
[m³]

8  
[cm]

125  
[kg]

160  
[°C]

7  
[g/s]

CE

EN 14785  
BlmSchV Stufe 2  
ART. 15a B-VG 2015  
REGENSBURGER/  
AACHENER/  
MÜNCHENER BStV



Conto Termico

CE

EN 14785  
BlmSchV Stufe 2  
ART. 15a B-VG 2015  
REGENSBURGER/  
AACHENER/  
MÜNCHENER BStV



Conto Termico

240\_Serpentino



102\_White

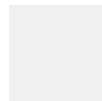

107\_Black



105\_Bordeaux





# Philo



## COMFORT AIR

**POWER<sub>max</sub>** 9 - 7.740  
[kW-kcal/h]

**POWER<sub>min</sub>** 3,2 - 2.752  
[kW-kcal/h]

87,8 / 93,6  
[%]



27  
[l]



pellet Ø 6-8 x 3÷40  
[mm]



~ 0,7 / ~ 2,0  
[kg/h]



~ 26 / ~ 9  
[h]



194/40 - 221/35 - 258/30  
[m³]



8  
[cm]



135  
[kg]



170  
[°C]



7,9  
[g/s]

# Stream



## COMFORT AIR \*\*\*

**POWER<sub>max</sub>** 12,4 - 10.664  
[kW-kcal/h]

**POWER<sub>min</sub>** 3,5 - 3.010  
[kW-kcal/h]

85,8 / 89,5  
[%]



42  
[l]



pellet Ø 6-8 x 3÷40  
[mm]



~ 0,8 / ~ 2,7  
[kg/h]



~ 34 / ~ 10  
[h]



260/40 - 297/35 - 347/30  
[m³]



8  
[cm]



175 [kg] (metal)  
225 [kg] (serpentino)



190  
[°C]



7,5  
[g/s]

CE

EN 14785

BlmSchV Stufe 2

ART. 15a B-VG 2015

REGENSBURGER/  
AACHENER/  
MÜNCHENER BStV



Conto Termico

302\_White

303\_Black

304\_Bordeaux

315\_Aluminium

305\_Bronze

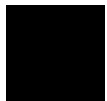
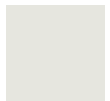

CE

EN 14785

BlmSchV Stufe 2

ART. 15a B-VG 2015

REGENSBURGER/  
AACHENER/  
MÜNCHENER BStV



Conto Termico

308\_Dark

302\_White

304\_Bordeaux

240\_Serpentino



# Flux



## HYDRO

<b>POWER max</b>	16,0 - 13.760 [kW-kcal/h] water 13,5 - 11.610 [kW-kcal/h]
<b>POWER min</b>	4,5 - 3.870 [kW-kcal/h] water 3,4 - 2.924 [kW-kcal/h]
	95,6 / 97,1 [%]
	33 [l]
	pellet Ø 6-8 x 3÷40 [mm]
	~ 1 / ~ 3,3 [kg/h]
	~ 21 / ~ 7 [h]
	344/40 - 393/35 - 459/30 [m²]
	8 [cm]
	180[kg]
	90 [°C]
	9,8 [g/s]

CE

EN 14785  
BlmSchV Stufe 2  
ART. 15a B-VG  
REGENSBURGER/  
AACHENER/  
MÜNCHENER BStV



V K F A E A I

Conto Termico  
BAFA  
RHI

302\_White

303\_Black

304\_Bordeaux

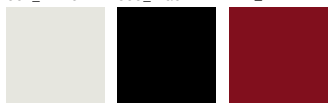

# Duo



## HYDRO AIR

<b>POWER max</b>	22,3-19.178 [kW-kcal/h] water 18-15.480[kW-kcal/h]
<b>POWER min</b>	4,4-3.784 [kW-kcal/h] water 3-2.580[kW-kcal/h]
	92,5 / 95 [%]
	44 [l]
	pellet Ø 6-8 x 3÷40 [mm]
	~ 0,9 / ~ 4,9 [kg/h]
	~ 28 / ~ 5 [h]
	481/40 - 550/35 - 642/30 [m²]
	8 [cm]
	190 [kg]
	160 [°C]
	12,6 [g/s]

CE

EN 14785  
BlmSchV Stufe 2  
ART. 15a B-VG 2015  
REGENSBURGER/  
AACHENER/  
MÜNCHENER BStV



V K F A E A I

Conto Termico  
BAFA

102\_White

107\_Black

105\_Bordeaux



# Swing



## HYDRO \*/\*\*

**POWER**  
max 24,8-21.328[kW-kcal/h]  
water 22,7-19.522[kW-kcal/h]

**POWER**  
min 6-5.160[kW-kcal/h]  
water 5-4.300[kW-kcal/h]

91,6 / 95,1  
[%]

106  
[l]

pellet Ø 6-8 x 3÷40  
[mm]

~ 1,2 / ~ 5,2  
[kg/h]

~ 60 / ~ 14  
[h]

533/40 - 609/35 - 711/30  
[m³]

10  
[cm]

210  
[kg]

120  
[°C]

17,1  
[g/s]

# Ego Hydro



## HYDRO

**POWER**  
max 11,6-9,976[kW-kcal/h]  
water 10-8.600[kW-kcal/h]

**POWER**  
min 3,6-3.096[kW-kcal/h]  
water 2,5-2.150[kW-kcal/h]

91,5 / 96  
[%]

37  
[l]

pellet Ø 6-8 x 3÷40  
[mm]

~ 0,8 / ~ 2,5  
[kg/h]

~ 36 / ~ 10  
[h]

249/40 - 285/35 - 333/30  
[m³]

8  
[cm]

175  
[kg]

140  
[°C]

9,4  
[g/s]

CE

EN 14785

BlmSchV Stufe 2

ART. 15a B-VG 2015

REGENSBURGER/  
AACHENER/  
MÜNCHENER BStV



Conto Termico  
RHI

102\_White

107\_Black

105\_Bordeaux



CE

EN 14785

BlmSchV Stufe 2

ART. 15a B-VG

REGENSBURGER/  
AACHENER/  
MÜNCHENER BStV



Conto Termico  
BAFA

302\_White

308\_Dark

313\_Silver

311\_Inox no  
touch

304\_Bordeaux



# Star Hydro



## HYDRO

<b>POWER max</b>	11,6-9,976[kW-kcal/h] water 10-8.600[kW-kcal/h]
<b>POWER min</b>	3,6-3.096[kW-kcal/h] water 2,5-2.150[kW-kcal/h]
	91,5 / 96 [%]
	37 [l]
	pellet Ø 6-8 x 3÷40 [mm]
	~ 0,8 / ~ 2,5 [kg/h]
	~ 36 / ~ 10 [h]
	249/40 - 285/35 - 333/30 [m³]
	8 [cm]
	175 [kg]
	140 [°C]
	9,4 [g/s]

# Musa Hydro



## HYDRO 15

<b>POWER max</b>	15,4-13.244 [kW-kcal/h] water 13-11.180[kW-kcal/h]
<b>POWER min</b>	4,4-3.784 [kW-kcal/h] water 3-2.580[kW-kcal/h]
	92,1 / 95 [%]
	44 [l]
	pellet Ø 6-8 x 3÷40 [mm]
	~ 0,9 / ~ 3,4 [kg/h]
	~ 32 / ~ 9 [h]
	332/40 - 379/35 - 443/30 [m³]
	8 [cm]
	190 [kg]
	145 [°C]
	10,4 [g/s]

## HYDRO 22 \*

<b>POWER max</b>	22,3-19.178 [kW-kcal/h] water 18-15.480[kW-kcal/h]
<b>POWER min</b>	4,4-3.784 [kW-kcal/h] water 3-2.580[kW-kcal/h]
	92,5 / 95 [%]
	44 [l]
	pellet Ø 6-8 x 3÷40 [mm]
	~ 0,9 / ~ 4,9 [kg/h]
	~ 28 / ~ 5 [h]
	481/40 - 550/35 - 642/30 [m³]
	8 [cm]
	190 [kg]
	160 [°C]
	12,6 [g/s]



EN 14785

BlmSchV Stufe 2

ART. 15a B-VG

REGENSBURGER/  
AACHENER/  
MÜNCHENER BStV



MCS BH0041 - HYDRO



Conto Termico  
BAFA

202\_Soapstone 110\_Salt and  
240\_Serpentino pepper



111\_Old amber



105\_Bordeaux



EN 14785

BlmSchV Stufe 2

ART. 15a B-VG 2015

REGENSBURGER/  
AACHENER/  
MÜNCHENER BStV



MCS BH0041 - HYDRO 15/22



Conto Termico  
BAFA



302\_White

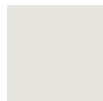

313\_Silver



308\_Dark



304\_Bordeaux



# Suite Hydro



	HYDRO 15	HYDRO 22 *
<b>POWER max</b>	15,4-13.244 [kW-kcal/h] water 13-11.180 [kW-kcal/h]	22,3-19.178 [kW-kcal/h] water 18-15.480 [kW-kcal/h]
<b>POWER min</b>	4,4-3.784 [kW-kcal/h] water 3-2.580 [kW-kcal/h]	4,4-3.784 [kW-kcal/h] water 3-2.580 [kW-kcal/h]
	92,1 / 95 [%]	92,5 / 95 [%]
	44 [l]	44 [l]
	pellet Ø 6-8 x 3÷40 [mm]	pellet Ø 6-8 x 3÷40 [mm]
	~ 0,9 / ~ 3,4 [kg/h]	~ 0,9 / ~ 4,9 [kg/h]
	~ 32 / ~ 9 [h]	~ 28 / ~ 5 [h]
	332/40 - 379/35 - 443/30 [m³]	481/40 - 550/35 - 642/30 [m³]
	8 [cm]	8 [cm]
	190 [kg]	190 [kg]
	145 [°C]	160 [°C]
	10,4 [g/s]	12,6 [g/s]

# Club Hydro



	HYDRO 15	HYDRO 22 *
<b>POWER max</b>	15,4-13.244 [kW-kcal/h] water 13-11.180 [kW-kcal/h]	22,3-19.178 [kW-kcal/h] water 18-15.480 [kW-kcal/h]
<b>POWER min</b>	4,4-3.784 [kW-kcal/h] water 3-2.580 [kW-kcal/h]	4,4-3.784 [kW-kcal/h] water 3-2.580 [kW-kcal/h]
	92,1 / 95 [%]	92,5 / 95 [%]
	44 [l]	44 [l]
	pellet Ø 6-8 x 3÷40 [mm]	pellet Ø 6-8 x 3÷40 [mm]
	~ 0,9 / ~ 3,4 [kg/h]	~ 0,9 / ~ 4,9 [kg/h]
	~ 32 / ~ 9 [h]	~ 28 / ~ 5 [h]
	332/40 - 379/35 - 443/30 [m³]	481/40 - 550/35 - 642/30 [m³]
	8 [cm]	8 [cm]
	190 [kg]	190 [kg]
	145 [°C]	160 [°C]
	10,4 [g/s]	12,6 [g/s]

CE

EN 14785

BImSchV Stufe 2

ART. 15a B-VG 2015

REGENSBURGER/  
AACHENER/  
MÜNCHENER BStV



MCS BH0041 - HYDRO 15/22

V K F A E A I

Conto Termico  
BAFA



CE

EN 14785

BImSchV Stufe 2

ART. 15a B-VG 2015

REGENSBURGER/  
AACHENER/  
MÜNCHENER BStV



MCS BH0041 - HYDRO 15/22

V K F A E A I

Conto Termico  
BAFA



110\_Salt and pepper



111\_Old amber



105\_Bordeaux



102\_White

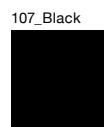

107\_Black

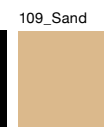

109\_Sand

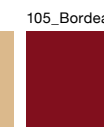













105\_Bordeaux



240\_Serpentino

# Legenda

	<b>POWER max</b> Potenza termica utile max [kW-kcal/h]	Nominal heat output [kW-kcal/h]	Puissance thermique utile max [kW-kcal/h]	Max Nutzheizleistung [kW-kcal/h]	Potencia térmica útil máx. [kW-kcal/h]
	<b>POWER min</b> Potenza termica utile min [kW-kcal/h]	Reduced heat output [kW-kcal/h]	Puissance thermique utile min [kW-kcal/h]	Min Nutzheizleistung [kW-kcal/h]	Potência térmica útil min [kW-kcal/h]
	Rendimento al max / al min [%]	Efficiency at max / at min [%]	Rendement au max / au min [%]	Kirkungsgrad bei Max.-Betr. / bei Min.-Betr. [%]	Rendimento al máx / al mín [%]
	Capacità serbatoio [l]	Hopper capacity [l]	Capacité du réservoir [l]	Fassungsvermögen Behälter [l]	Capacidad depósito [l]
	Tipo di combustibile	Fuel type	Type de combustible	Brennstoffart	Tipo de combustible
	Consumo orario (min/max) [kg/h]	Hourly consumption (min/max) [kg/h]	Consommation horaire (min/max) [kg/h]	Stündlicher Verbrauch (min/max) [kg/h]	Consumo por hora mín./máx [kg/h]
	Autonomia (al min/al max) [h]	Runtime (at min/at max)[h]	Autonomie (au min/au max) [h]	Autonomie (bei Mindestleistung/bei Höchstleistung) [h]	Autonomía al mín./al máx [h]
	Volume riscaldabile • [m³]	Heatable volume • [m³]	Volume de chauffe • [m³]	Raumheizvermögen • [m³]	Volumen que puede calentarse • [m³]
	Diametro uscita fumi [cm]	Diameter of smoke outlet pipe [cm]	Diamètre de sortie des fumées [cm]	Durchmesser Rauchabzug [cm]	Diámetro salida humos [cm]
	Peso [kg]	Weight [kg]	Poids [kg]	Gewicht [kg]	Peso [kg]
	Temperatura fumi [°C]	Smoke temperature [°C]	Température des fumées [°C]	Rauchgastemperatur [°C]	Temperatura humos [°C]
	Portata massica dei fumi [g/s]	Massive smoke capacity [g/s]	Débit massique des fumées [g/s]	Massenreichweite des Rauchs [g/s]	Caudal en masa de humos [g/s]

•

\_Volume riscaldabile a seconda del bisogno di 40-35-30 kcal/h per m<sup>3</sup>.  
\_Heatable volume based on needs of 40-35-30 kcal/h per m<sup>3</sup>.  
\_Volume de chauffe, selon le bosoin, de 40-35-30 kcal/h per m<sup>3</sup>.  
\_Beheizbares Volumen je nach dem Bedarf an 40-35-30 kcal/h per m<sup>3</sup>.  
\_Volumen que puede calentarse en función de las necesidades de 40-35-30 kcal/h per m<sup>3</sup>.

\*

\_Disponibile con scambiatore per la produzione di acqua sanitaria.  
\_Available with an exchanger for dhw production.  
\_Disponibile avec un échangeur pour la production d'eau sanitaire.  
\_Ist mit einem austauscher für die produktion von sanitärwasser verfügbar.  
\_Equipada con intercambiador para la producción de agua sanitaria.

\*\*

\_Stufa Hydro dotata di ventilatore ambiente.  
\_Hydro stove equipped with room fan.  
\_Poêle Hydro doté d'un ventilateur ambiant.  
\_Mit Raumgebläse ausgestattet waserführender Ofen.  
\_Estufa hydro equipada con ventilador ambiente.

\*\*\*

\_In corso di certificazione.  
\_Certification currently in progress.  
\_En cours de certification.  
\_Zertifizierung wird gerade ausgeführt.  
\_En curso de certificación.

	Ego Air / Comfort Air	Ego Hydro	Star Air / Comfort Air	Star Hydro	Musa Air / Comfort Air	Musa Hydromatic <span style="color:red">NEW</span>	Musa Hydro	Suite Air / Comfort Air	Suite Hydromatic <span style="color:red">NEW</span>	Suite Hydro	Club Air / Comfort Air	Club Hydromatic <span style="color:red">NEW</span>	Club Hydro	Curve <span style="color:red">NEW</span>	Mood <span style="color:red">NEW</span>	Halo <span style="color:red">NEW</span>	Aike Air Oyster	Aike Comfort Air	Klin	Tilda	Stream	Flux
	●		●		●			●			●					●	●					
	●		●		●			●			●		●	●				●	●	●	●	
		●		●		●	●		●	●		●	●									●
																					●	●
	●																				●	●
														●	●	●						
	●		●		●	●		●	●		●	●		●	●	●	●	●	●	●	●	
														●	●	●						
						●			●			●		●	●	●						
						●			●			●										
						●			●			●		●	●	●						
		●		●			●			●			●									●
	●		●		●	●		●	●		●	●		●	●	●	●	●	●	●	●	
GPRS READY!	○	○	○	○	○	○	○	○	○	○	○	○	○	○	○	○	○	○	○	○	○	○
	○		○		○	○		○	○		○	○		○	○	○	○	○	○	○	○	○
		●		●			●			●			●									
	●		●		●	●		●	●		●	●		●	●	●	●	●	●	●	●	●
	●				●			●			●		●	●	●	●	●					
	p.161	p.170	p.157	p.171	p.160	p.160	p.171	p.158	p.158	p.172	p.159	p.159	p.172	p.152	p.152	p.153	p.155	p.155	p.154	p.154	p.168	p.169

● Standard

○ Optional

✕ Canalizzabile / Ductable / Canalisable / Kanalisierbar / Canalizable

	Flat	Flair	Philo	Decò	Cute	Thema	Kaika	Amy	Face	Giò	Maggie	Lam	Tray	Cap	Toba Air / Comfort Air	Toba Hydro	Tube	Sagar	Nima	Duo	Swing	Vivo 90 Comfort Air	Vivo 80 Comfort Air	Vivo 80 Hydro	Vivo 85 Hydro	Boxtherm 70/60
p.167																										
p.167		●																								
p.168		●	●																							
p.165		●	●	●	●	●	●	●	●	●	●	●	●	●	●	●	●	●	●	●	●	●	●	●	●	●
p.164		●	●	●	●	●	●	●	●	●	●	●	●	●	●	●	●	●	●	●	●	●	●	●	●	●
p.165		●	●	●	●	●	●	●	●	●	●	●	●	●	●	●	●	●	●	●	●	●	●	●	●	●
p.162		●	●	●	●	●	●	●	●	●	●	●	●	●	●	●	●	●	●	●	●	●	●	●	●	●
p.163		●	●	●	●	●	●	●	●	●	●	●	●	●	●	●	●	●	●	●	●	●	●	●	●	●
p.164		●	●	●	●	●	●	●	●	●	●	●	●	●	●	●	●	●	●	●	●	●	●	●	●	●
p.156		●	●	●	●	●	●	●	●	●	●	●	●	●	●	●	●	●	●	●	●	●	●	●	●	●
p.157		●	●	●	●	●	●	●	●	●	●	●	●	●	●	●	●	●	●	●	●	●	●	●	●	●
p.156		●	●	●	●	●	●	●	●	●	●	●	●	●	●	●	●	●	●	●	●	●	●	●	●	●
p.153		●	●	●	●	●	●	●	●	●	●	●	●	●	●	●	●	●	●	●	●	●	●	●	●	●
p.153		●	●	●	●	●	●	●	●	●	●	●	●	●	●	●	●	●	●	●	●	●	●	●	●	●
p.166		●	●	●	●	●	●	●	●	●	●	●	●	●	●	●	●	●	●	●	●	●	●	●	●	●
p.155		●	●	●	●	●	●	●	●	●	●	●	●	●	●	●	●	●	●	●	●	●	●	●	●	●
p.166		●	●	●	●	●	●	●	●	●	●	●	●	●	●	●	●	●	●	●	●	●	●	●	●	●
p.169		●	●	●	●	●	●	●	●	●	●	●	●	●	●	●	●	●	●	●	●	●	●	●	●	●
p.170		●	●	●	●	●	●	●	●	●	●	●	●	●	●	●	●	●	●	●	●	●	●	●	●	●
p.142		●	●	●	●	●	●	●	●	●	●	●	●	●	●	●	●	●	●	●	●	●	●	●	●	●
p.144		●	●	●	●	●	●	●	●	●	●	●	●	●	●	●	●	●	●	●	●	●	●	●	●	●
p.146		●	●	●	●	●	●	●	●	●	●	●	●	●	●	●	●	●	●	●	●	●	●	●	●	●
p.148		●	●	●	●	●	●	●	●	●	●	●	●	●	●	●	●	●	●	●	●	●	●	●	●	●
p.150		●	●	●	●	●	●	●	●	●	●	●	●	●	●	●	●	●	●	●	●	●	●	●	●	●



# Legenda

	Convezione naturale	Convection versions	Convection naturelle	Natürlicher konvektion	Convección natural
	Ventilazione forzata	Forced ventilation	Ventilation forcée	Zwangsbelüftung	Ventilación forzada
	Aria canalizzata	Ducted air	Air canalisé	Luftverteilung	Aire canalizado
	Acqua/aria	Water/air	Eau/air	Wasser/luft	Agua/aire
	Acqua	Water	Eau	Wasserführende	Agua
	Spazi ristretti	Confined spaces	Espaces étroits	In engen Räumlichkeiten	Espacios estrechos
	Recupero vecchi focolari	Use of old fireboxes	Récupération des Anciens foyers	Wiederverwertung von Alten feurräumen	Recuperación de viejas chimeneas
	Recupero canne Fumarie esistenti	Use of existing flues	Récupération des conduits de fumée existants	Wiederverwertung von bereits existierenden schornsteinen	Recuperación de conductos de humos existentes
	Soluzioni ad angolo	Corner solutions	Solutions à angle	Eckenlösungen	Soluciones de esquina
	Zero rumore	Noise-free	Aucun bruit	Geräuschlos	Sin ruidos
	Ventilazione escludibile	Excludable ventilation	Ventilation désactivable	Ausschliessbare Lüftung	Ventilación con posibilidad de exclusión
	Fiamma naturale	Natural flame	Flamme naturelle	Natürliche flamme	Llama natural
	Accensione In 3 minuti	Ignition in 3 minutes	Allumage en 3 minutes	Einschaltung in 3 minuten	Encendido en 3 minutos
	Braciere autopulente	Self-cleaning brazier	Brasier autonettoyant	Selbstreinigende brennschale	Brasero autolimpiador
	Svuotamento cenere settimanale	Weekly ash emptying	Vidage des cendres hebdomadaire	Wöchentliche aschenentleerung	Vaciado de las cenizas semanal
	Pannello	Panel	Panneau	Bedienfeld	Panel
	Telecomando con termostato ambiente	Remote control with room thermostat	Tèlècommande avec thermostat ambiance	Fernbedienung mit Raumthermostat	Mando con función termostato ambiente
	GPRS ready	GPRS ready	GPRS ready	GPRS ready	GPRS ready
	Smartphone e tablet	Smartphone and tablet	Smartphone et tablet	Smartphone und Tablet	Smartphone y tablet
	Active	Active	Active	Active	Active
	Active plus	Active plus	Active plus	Active plus	Active plus
	Oyster	Oyster	Oyster	Oyster	Oyster